

PT190/PT192/PT193 Series

Comply with SIL2 and PL'c' safety performance standard

Remotely autozero via shorting 2pins together



Certification :

ISO9001-2015



Content

- 1. Introduction _____
- 2. Application _____
- 3. Product features _____
- 4. Technical data _____
- 5. Dimensions _____
- 6. Electrical connection and debugging _____
- 7. Ordering Guide _____
- 8. Installation and Removal _____
- 9. Sensors cleaning _____
- 10. Transport and storage _____

1. Introduction

PT190/TP192/PT193 Melt pressure sensor adapt TI series high-performance digital chips. The circuit design is based on SIL2, PL'c' safety performance standards. The range limit is controlled through the relay output to ensure the safety of the extrusion equipment and production line, and effectively reduce the impact of damage and unpredictable personal safety accidents on the equipment due to pressure overload.

2. Application

PT190/TP192/PT193 melt pressure sensors are suitable for extrusion equipment and production lines with precise process control.

3. Product Features

- Pressure range: 0 ~ 35bar to 0 ~ 2000bar
- Accuracy grade: $\pm 0.5\%$, $\pm 0.25\%$
- Remotely autozero via shorting 2pins together
- PL'c' safety performance level
- Special diaphragm coating, resistance to melt cooling adhesion diaphragm damage
- Digital-analog integrated circuit design, super anti-interference

4. Technical Data

Pressure Range	0~35bar;0~2000bar		0~100bar;0~2000bar
Accuracy	$\pm 0.5\%$ 、 $\pm 0.25\%$		
Over load Pressure	1.5FSO		
Bridge Resistance	350 Ω Wheatstone bridge		
Power	15 ~ 36Vdc	6 ~ 12Vdc	
Output Signal	4 ~ 20mA	3.33mV/V	
Relay Contact Performance	5 ~ 220Vdc, 1A, 0.2%FSO		
Relay Output	Open	Output percent	10%,20%...100%
Load Resistance (Ω)	< 500 Ω		—
Calibration	80%FSO		
Process Connection	M14×1.5、1/2-20UNF、M18×1.5		
Insulation Resistance (50Vdc)	1000M Ω		
Diaphragm Material	17-4PH、inconel718、C276		
Diaphragm max temp	400C°		
Film Material	TiAlN		
E-connection	7-pin connector(Standard), 8-pin connector		
Electrical Environment temp	-20C° ~ 85C°		
Thermocouple	J Type,E Type,K Type,pt100		
Protection Degree	IP65		
Installation torque	< 30Nm		
Filling Material	Alloy-filling or Mercury filling		

4...20mA Alarm output data

Power	Output	Relay status
Power off	No signal	On
Power off	< alarm point	OFF
Power off	\geq alarm point	On
Power off	Abnormal output < 3.6mA	On

6. Electrical connection & Debugging

After the pressure sensor has been installed on the pipeline, the electrical connection must be carried out in accordance with the connection mode shown in the wiring diagram below. This series is equipped with an integrated amplifier circuit. The calibration process must be that the pipeline is heated and the pressure is zero, and the zero point is adjusted by activating the autozero function, which is started by shorting two pins together, mV signal does not have this function, can be rezero through the back-end instrument. Then 80% of the output signal is detected (see wiring diagram), and the pressure sensor (transmitter) will provide a standard 80% measured value signal.

4...20mA (3-wire)

(S3)7-pin connector :62IN-5016-10-7P-4-M(AMPHENOL)

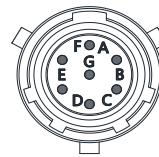
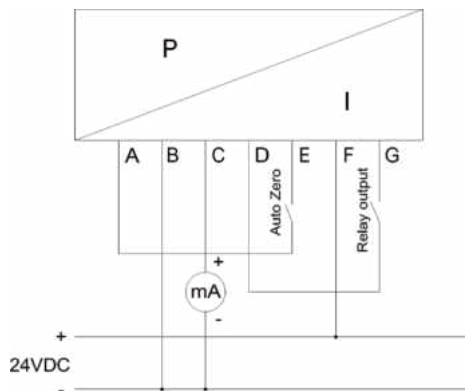

PIN	Function	Wire Color
A	Shorting A&E to rezero +	Red
B	Power - /Signal -	Black
C	Signal +	White
D	Relay output +	Green
E	Shorting A&E to rezero -	Blue
F	Power +	Yellow
G	Relay output -	Grey

4...20mA (3-wire)

(S9) 8-pinconnector : M16 DIN/EN45326(Binder)

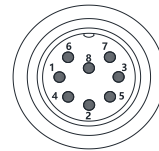
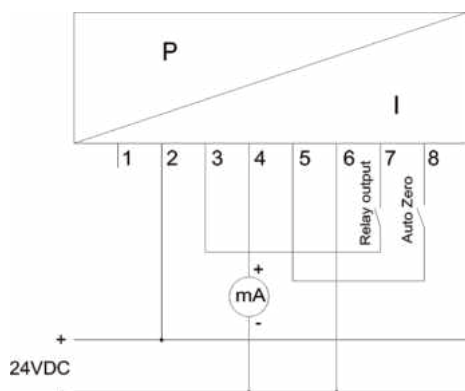

PIN	Function	Wire Color
1	Shorting 5&8 to rezero +	Green
2	Power +	Red
3	Relay output +	Yellow
4	Signal +	Black
5	Shorting 5&8 to rezero +	Grey
6	Power - /Signal -	White
7	Relay output -	Blue
8	Shorting 5&8 to rezero -	Brown

4...20mA (3-wire)

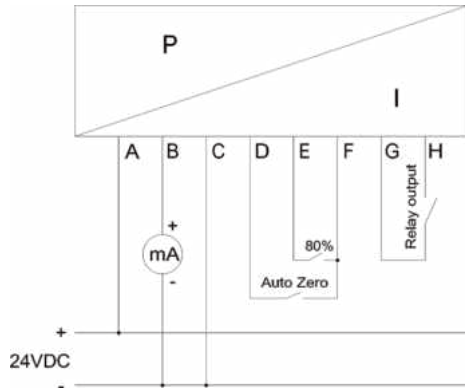

(S6) 8-pin connector : PT02A-10-8P

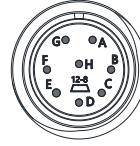

PIN	Function	Wire Color
A	Power +	Red
B	Power +	Black
C	Power - /Signal -	White
D	Shorting D&F to rezero +	Green
E	80% +	Blue
F	Shorting D&F to rezero - /80% -	Yellow
G	Relay output +	Grey
H	Relay output -	Brown

3.33mV/V (3-wire)

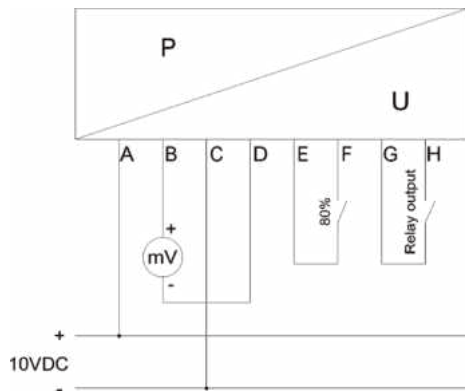

(S8) 8-pin connector : PT02A-10-8P

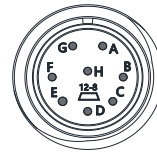

PIN	Function	Wire Color
A	Power +	Red
B	Signal +	Black
C	Power -	White
D	Signal -	Green
E	80% +	Blue
F	80% -	Yellow
G	Relay Output +	Grey
H	Relay Output -	Brown

Cable shall be made with shield cable, and the temperature resistance of each core shall not be less than 105 C°. Each core connection column shall be insulated and protected by heat shrink pipe, and the shield wire shall be connected to the plug metal. Special care shall be taken during cable welding, otherwise it may lead to wrong signal transmission or damage the product. It is recommended to use the welded special cable wire by Ziasiot . For excess wires in the cable, each wire shall be wrapped with insulating tape.

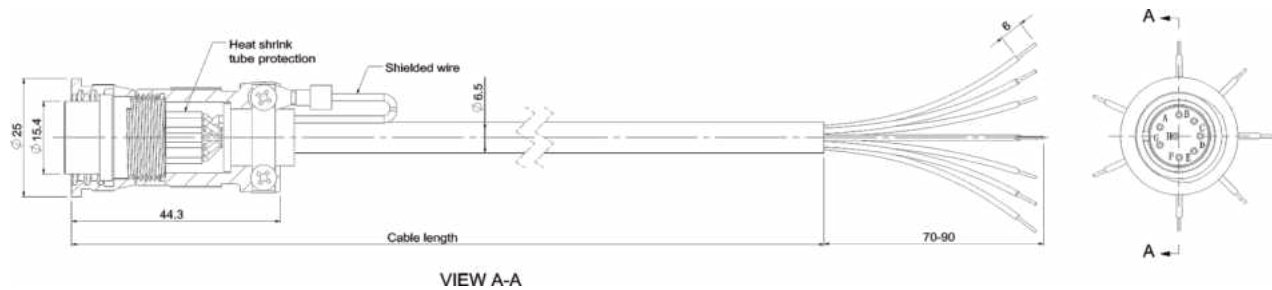

7. Ordering Guide

Serie No	PT	X	X	X	X	X	X	X	X	X	X	X	X
Product Type	Rigid Stem	190											
	Rigid+flexible stem	192											
	With thermocouple	193											
Pressure Range	3.5MPa 35bar 500psi	5C											
	10MPa 100bar 1500psi	1.5M											
	20MPa 200bar 3000psi	3M											
	35MPa 350bar 5000psi	5M											
	50MPa 500bar 7500psi	7.5M											
	70MPa 700bar 10000psi	10M											
	100MPa 1000bar 15000psi	15M											
	200MPa 2000bar 30000psi	30M											
Process Connection	1/2-20UNF	1/2											
	M14×1.5	M14											
	M18×1.5	M18											
Rigid stem Length	6" (152mm)	6											
	9" (229mm)	9											
	12.5" (318mm)	12											
	15" (381mm)	15											
	18" (460mm)	18											
Flexible stem Length	18" (460mm)	/18											
	24" (610mm)	/24											
	30" (760mm)	/30											
Output Signal	4-20mA 7-pin connector (p/n 62IN-5016-10-7P-4-M) (AMPHENOL)	S3											
	4-20mA 8-pin connector(p/n PT02A-10-8P)	S6											
	3.33mV/V 8-pin connector(p/n PT02A-10-8P)	S8											
	4-20mA 8-pin connector (p/n M16 DIN/EN45326)(Binder)	S9											
Thermocouple	J Type	J											
	K Type	K											
	Pt100	RTD1											
Relay Alarm	70% relay output	GC7											
	80% relay output	GC8											
	90% relay output	GC9											
	100% relay output	GC10											
Filling Medium	Mercury filling(Standard)	--											
	Alloy filling	EP											
Accuracy	0.50%	--											
	0.25%	2A											
Diaphragm	17-4PH(Standard)	--											
	inconel718 (Anti-abrasive)	I7											
	C276 (Anti-corrosive)	C2											

8. Installation & Removal

Installation

When installing the pressure sensor, the sensor hole should be within the size requirement marked in following drawing and the assembly accuracy can be checked by testing bolts. Before installing the sensor, first clean the impurities in the hole and between the threads, then the thread of the sensor is coated with heat-resistant slurry, the screw teeth can be avoided.

The installation force is very important, the installation torque of the sensor can only act on the shaft (hexagon), do not apply any force to the head of the sensor. The housing should be kept away from high temperature areas.

1/2-20 UNF /M14×1.5= Maximum starting torque : 40Nm

M18 x 1.5 =Maximum starting torque : 50 Nm

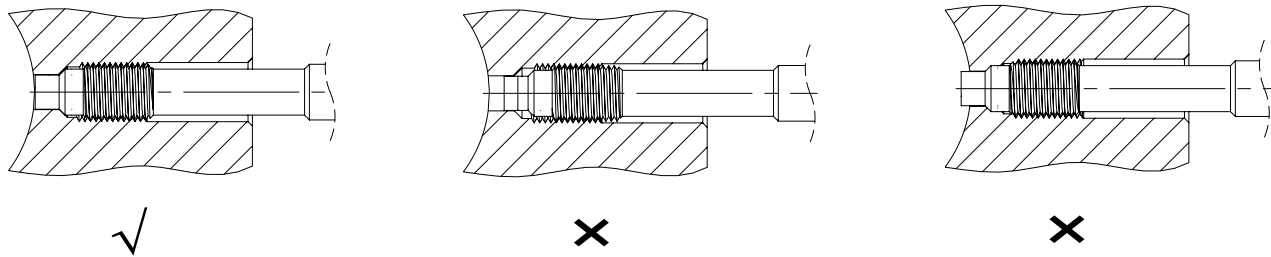

Removal

The removal of the pressure sensor must be done under heating conditions (plastic melting point). When removing the sensor, note that the diaphragm has no contact pressure. The force to unload the sensor must be applied only on the shaft (hexagon) and no force is applied to the head of the sensor.

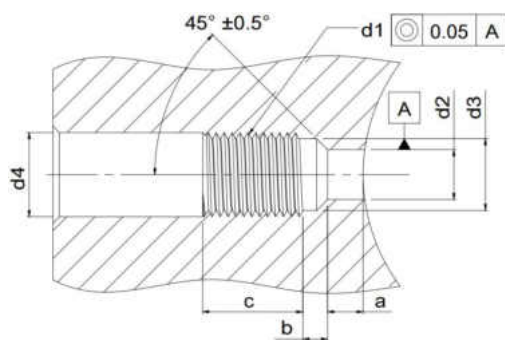

d1	M18×1.5	M14×1.5	1/2-20UNF-2A
d2	Ø9.9 ^{+0.1}	Ø7.9 ^{+0.1}	Ø7.9 ^{+0.1}
d3	Ø16.1 ^{+0.1}	Ø11.7 ^{+0.1}	Ø10.7 ^{+0.1}
d4	Ø20	Ø15	Ø14
a	6.1 ^{-0.1}	5.7 ^{-0.1}	5.7 ^{-0.1}
b	4 ^{-0.2}	3.2 ^{-0.2}	3.2 ^{-0.2}
c	25	19	19

9. Sensors cleaning

In order to clean the diaphragm, the sealing surface and thread of the transmitter must have the same temperature as the melting point of the plastic. The diaphragm and sealing surface can be cleaned with soft cloth, and the thread and rigid rod can be cleaned with steel brush or copper brush. (Do not touch diaphragm surface with steel brush)

10. Transport and storage

PT190/TP192/PT193 pressure sensor (transmitter) is usually packed separately. At the front thread of the rigid rod, the induction diaphragm is protected by a protective cap. This protective cap should be tightened at any time during storage, and only opened during installation.

Note: Mounting brackets, extension cables, connectors, cleaning kits, drill kits, dummy plug etc accessories, please contact with us.