

Technical Information

Waterpilot FMX21

Hydrostatic level measurement

Compact transmitter for level measurement



Application

The Waterpilot FMX21 is a pressure sensor for hydrostatic level measurement.

Endress+Hauser offers three different versions of the device:

- FMX21 with a stainless steel housing, external diameter of 22 mm (0.87 in): This version is excellently suited to drinking water applications and for use in bore holes and wells with small diameters
- FMX21 with a stainless steel housing, external diameter of 42 mm (1.65 in): Heavy-duty version and easy to clean thanks to flush-mounted process isolating diaphragm, ideally suited to wastewater and wastewater treatment plants
- FMX21 with plastic insulation, external diameter of 29 mm (1.14 in): Robust version for use in salt water and excellently suited to applications on ships (e.g. ballast water tanks)

Your benefits

- High resistance to overload
- High-precision, robust ceramic measuring cell with long-term stability
- Climate proofed sensor thanks to completely potted electronics and 2-filter pressure compensation system
- Simultaneous measurement of level and temperature with optionally integrated Pt100 temperature sensor
- Accuracy
 - Standard reference accuracy $\pm 0.2\%$
 - PLATINUM version $\pm 0.1\%$
- Automatic density compensation to increase accuracy
- Usage in drinking water: KTW, NSF, ACS
- Approvals: ATEX, FM, CSA
- Marine approvals: GL, ABS, BV, DNV
- Extensive range of accessories provides complete measuring point solutions

Table of contents

About this document	4	Cable marking	29
Document function	4	Cable shortening kit	29
Symbols	4	Environment	30
Documentation	5	Ambient temperature range	30
Terms and abbreviations	6	Storage temperature range	30
Turn down calculation	7	Degree of protection	30
Function and system design	8	Electromagnetic compatibility (EMC)	31
Device version	8	Overvoltage protection	31
Measuring principle	8	Process	32
Measuring system	10	Medium temperature range	32
Level measurement with absolute pressure probe and external pressure signal	12	Medium temperature limit	32
Density compensation with the Pt100 temperature sensor	12	Pressure specifications	33
Communication protocol	13	Mechanical construction	34
System integration	13	Dimensions of the level probe	34
Input	14	Dimensions of the suspension clamp	35
Measured variable	14	Dimensions of the cable mounting screw	35
Measuring range	14	Dimensions of terminal box IP66, IP67 with filter	36
Input signal	15	Dimensions of the TMT71 temperature head transmitter	37
Output	16	Dimensions of the TMT72 temperature head transmitter	37
Output signal	16	Terminal box with integrated TMT71 temperature head transmitter	38
Signal range	16	Terminal box with integrated TMT72 temperature head transmitter	38
Maximum load	16	Additional weight	39
Maximum load	16	Testing adapter	39
Damping	17	RIA15 in the field housing	40
Protocol-specific data	18	HART communication resistor	40
Power supply	19	Weight	41
Supply voltage	19	Materials	42
Power consumption	19	Operability	46
Current consumption	19	FMX21 4 to 20 mA Analog	46
Connecting the device	19	FMX21 4 to 20 mA HART	46
Terminals in the terminal box	24	RIA15	46
Probe cable	24	Certificates and approvals	47
Cable resistance	24	CE mark	47
Cable specifications	24	RCM marking	47
Residual ripple	24	EAC conformity	47
Residual ripple	24	Drinking water approval	47
Performance characteristics	25	Marine approval	47
Reference operating conditions	25	Other standards and guidelines	48
Reference accuracy	25	Calibration	48
Resolution	25	Calibration unit	48
Long-term stability	26	Service	48
Influence of medium temperature	26	Downloading the Declaration of Conformity	48
Warm-up time	26	Ordering information	49
Response time	26	Scope of delivery	49
Mounting	27	Test reports, declarations and inspection certificates	49
Installation instructions	27	Configuration data sheet	49
Additional installation instructions	27	Accessories	51
Cable length	28	Service-specific accessories	54
Technical data for cable	29		

Supplementary documentation	55
Field of Activities	55
Technical Information	55
Operating Instructions	55
Brief Operating Instructions	55
Safety Instructions (XA)	55
Drinking water approval	55
Registered trademarks	55
GORE-TEX®	55
TEFLON®	55
HART®	55
FieldCare®	55
DeviceCare®	55
iTEMP®	55

About this document

Document function

The document contains all the technical data on the device and provides an overview of the accessories and other products that can be ordered for the device.

Symbols

Safety symbols



This symbol alerts you to a dangerous situation. Failure to avoid this situation will result in serious or fatal injury.



This symbol alerts you to a dangerous situation. Failure to avoid this situation can result in serious or fatal injury.



This symbol alerts you to a dangerous situation. Failure to avoid this situation can result in minor or medium injury.



This symbol contains information on procedures and other facts which do not result in personal injury.

Electrical symbols



Direct current



Alternating current



Direct and alternating current



Ground connection

Grounded clamp, which is grounded via a grounding system.



Protective earth (PE)

Ground terminals, which must be grounded prior to establishing any other connections. The ground terminals are located on the inside and outside of the device.



Equipotential connection

A connection that has to be connected to the plant grounding system: This may be a potential equalization line or a star grounding system depending on national or company codes of practice.

Symbols for certain types of information



Permitted

Procedures, processes or actions that are permitted



Preferred

Procedures, processes or actions that are preferred



Forbidden

Procedures, processes or actions that are forbidden



Tip

Indicates additional information



Reference to documentation



Reference to page



Reference to graphic

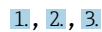

Series of steps



Result of a step



Help in the event of a problem



Visual inspection

Symbols in graphics

1, 2, 3, ...

Item numbers

1, 2, 3

Series of steps

A, B, C, ...

Views

A-A, B-B, C-C etc.

Sections

Documentation

The following types of documentation are available in the Download Area of the Endress+Hauser website (www.endress.com/downloads):



For an overview of the scope of the associated Technical Documentation, refer to the following:

- *W@M Device Viewer* (www.endress.com/deviceviewer): Enter the serial number from the nameplate
- *Endress+Hauser Operations App*: Enter the serial number from the nameplate or scan the matrix code on the nameplate

Operating Instructions (BA)

Your reference guide

These Operating Instructions contain all the information that is required in various phases of the life cycle of the device: from product identification, incoming acceptance and storage, to mounting, connection, operation and commissioning through to troubleshooting, maintenance and disposal.

Brief Operating Instructions (KA)

Guide that takes you quickly to the 1st measured value

The Brief Operating Instructions contain all the essential information from incoming acceptance to initial commissioning.

Safety Instructions (XA)

Depending on the approval, the following Safety Instructions (XA) are supplied with the device. They are an integral part of the Operating Instructions.



The nameplate indicates the Safety Instructions (XA) that are relevant to the device.

Terms and abbreviations

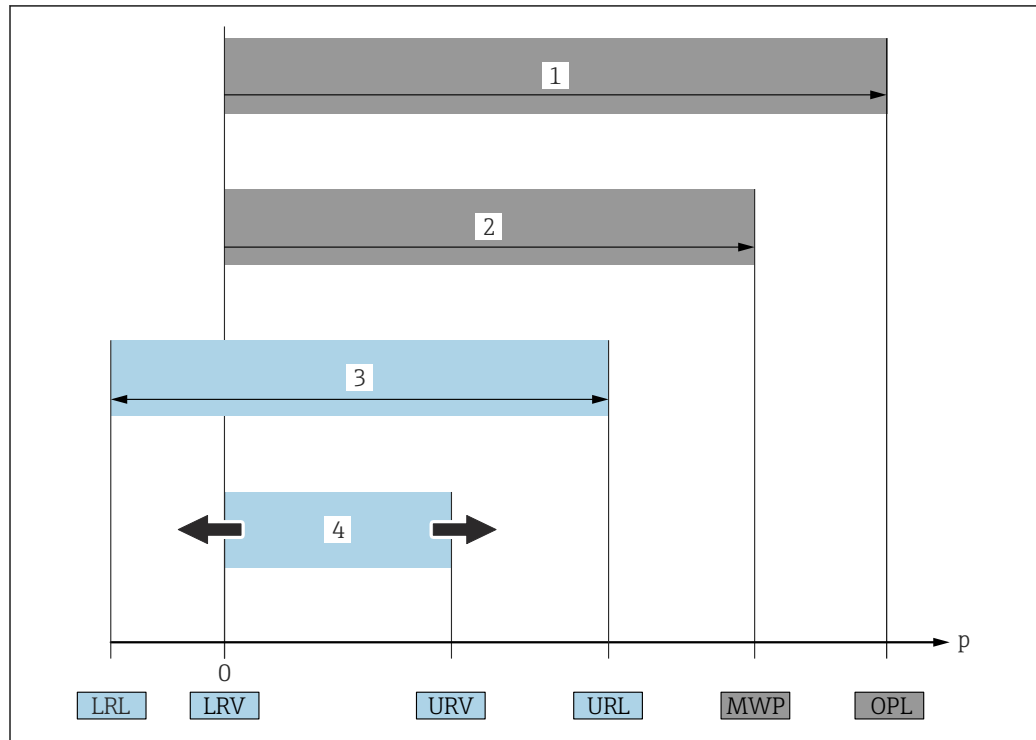

A0029505

- **OPL (1)**

The OPL (Over Pressure Limit) for the measuring device depends on the lowest-rated element, with regard to pressure, of the selected components i.e. the process connection has to be taken into consideration in addition to the measuring cell. Also observe pressure-temperature dependency.

The OPL may only be applied for a limited period of time.

- **MWP (2)**

The MWP (Maximum Working Pressure) for the sensors depends on the lowest-rated element, with regard to pressure, of the selected components, i.e. the process connection has to be taken into consideration in addition to the measuring cell. Also observe pressure-temperature dependency.

The MWP may be applied at the device for an unlimited period.

The MWP can also be found on the nameplate.

- **Maximum sensor measuring range (3)**

Span between LRL and URL. This sensor measuring range is equivalent to the maximum calibratable/adjustable span.

- **Calibrated/adjusted span (4)**

Span between LRV and URV. Factory setting: 0 to URL

Other calibrated spans can be ordered as customized spans.

- **p:** Pressure

- **LRL:** Lower range limit

- **URL:** Upper range limit

- **LRV:** Lower range value

- **URV:** Upper range value

- **TD (Turn down):** Example - see the following section

- **PE:** Polyethylene

- **FEP:** Fluorinated ethylene propylene

- **PUR:** Polyurethane

Turn down calculation

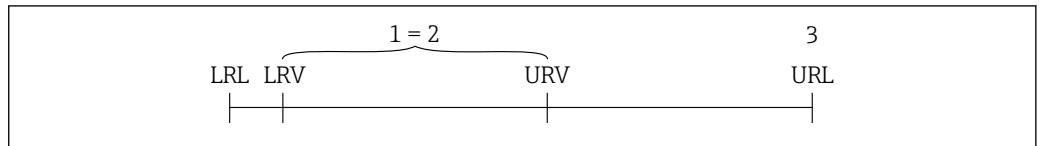

A0029545

- 1 Calibrated/adjusted span
- 2 Zero point-based span (4 to 20 mA Analog: customer-specific span can only be set at the factory when ordered)
- 3 URL sensor

Example

- Sensor: 10 bar (150 psi)
- Upper range value (URL) = 10 bar (150 psi)
- Calibrated/adjusted span: 0 to 5 bar (0 to 75 psi)
- Lower range value (LRV) = 0 bar (0 psi)
- Upper range value (URV) = 5 bar (75 psi)



Turn down (TD):

$$TD = \frac{URL}{|URV - LRV|}$$

$$TD = \frac{10 \text{ bar (150 psi)}}{|5 \text{ bar (75 psi)} - 0 \text{ bar (0 psi)}|} = 2$$

In this example, the TD is 2:1.
This span is based on the zero point.

Function and system design

External diameter	22 mm (0.87 in)	42 mm (1.65 in)	Max. 29 mm (1.14 in)
	 A0018640	 A0018641	 A0018642
Field of application	Hydrostatic level measurement in deep wells e.g. drinking water	Hydrostatic level measurement in wastewater	Hydrostatic level measurement in saltwater
	<p>NOTICE The Waterpilot is not suitable for use in biogas plants since the gases can diffuse through the elastomers (seals, cable). ▶ For applications involving biogas, Endress+Hauser offers the Deltapilot level measuring device.</p>		
Process connection	<ul style="list-style-type: none"> ▪ Suspension clamp ▪ Cable mounting screw with G 1½" A or NPT 1½" thread 		
Extension cable	PE, PUR, FEP → ☞ 45		
Seals	<ul style="list-style-type: none"> ▪ FKM Viton ▪ EPDM ¹⁾ 	FKM Viton	<ul style="list-style-type: none"> ▪ FKM Viton ▪ EPDM ¹⁾
Measuring ranges	<ul style="list-style-type: none"> ▪ Gauge pressure: 0 to 0.1 bar (0 to 1.5 psi) to 0 to 20 bar (0 to 300 psi) ▪ Absolute pressure: 0 to 2 bar (0 to 30 psi) to 0 to 20 bar (0 to 300 psi) 		<ul style="list-style-type: none"> ▪ Gauge pressure: 0 to 0.1 bar (0 to 1.5 psi) to 0 to 4 bar (0 to 60 psi) ▪ Absolute pressure: 0 to 2 bar (0 to 30 psi) to 0 to 4 bar (0 to 60 psi)
	<ul style="list-style-type: none"> ▪ Customer-specific measuring ranges; factory-calibrated. ▪ The following output units can be configured: %, mbar, bar, kPa, MPa, mmH₂O, mH₂O, inH₂O, ftH₂O, psi and numerous level units. 		
Overload	To 40 bar (600 psi)		To 25 bar (375 psi)
Process temperature range	-10 to +70 °C (+14 to +158 °F)		0 to +50 °C (+32 to +122 °F)
Reference accuracy	<ul style="list-style-type: none"> ▪ ±0.2 % of set span ▪ Optional: ±0.1 % of set span (PLATINUM version) 		
Supply voltage	10.5 to 35 V _{DC} , Ex: 10.5 to 30 V _{DC}		
Output	<ul style="list-style-type: none"> ▪ 4 to 20 mA Analog ▪ 4 to 20 mA HART (can be inverted) with superimposed digital communication protocol HART 6.0, 2-wire 		
Options	Drinking water approval	—	
	<ul style="list-style-type: none"> ▪ Wide range of approvals, including ATEX, FM, CSA ▪ Numerous accessories ▪ Integrated Pt100 temperature sensor and TMT71 temperature head transmitter (4 to 20 mA) ▪ Integrated Pt100 temperature sensor and TMT72 temperature head transmitter (4 to 20 mA) ▪ Marine approval 		
Specialties	<ul style="list-style-type: none"> ▪ High-precision, robust ceramic measuring cell with long-term stability ▪ Automatic density compensation ▪ Customer-specific cable marking 		

1) Recommended for drinking water applications, not suitable for use in hazardous areas.

Measuring principle

The ceramic measuring cell is a dry measuring cell i.e. the pressure acts directly on the robust, ceramic process isolating diaphragm of the Waterpilot FMX21. Changes in air pressure are guided

via a pressure compensation tube through the extension cable to the rear of the ceramic process isolating diaphragm and are compensated for. A pressure-dependent change in capacitance, caused by the movement of the process isolating diaphragm, is measured at the electrodes of the ceramic carrier. The electronics unit then converts this to a signal that is proportional to the pressure and linear to the level.

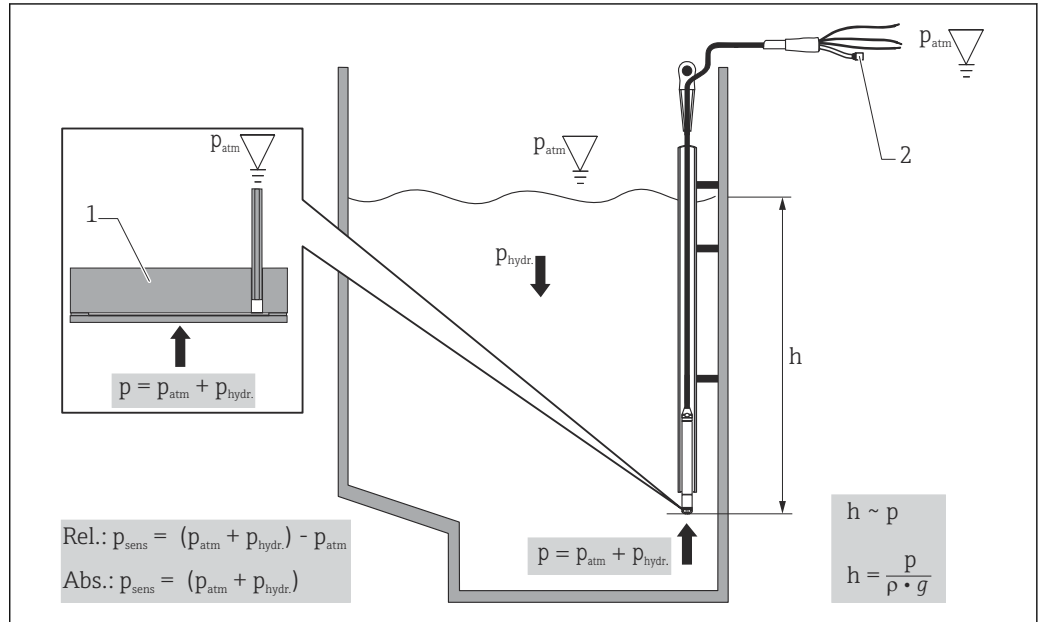

- 1 Ceramic measuring cell
 2 Pressure compensation tube
 h Height level
 p Total pressure = atmospheric pressure + hydrostatic pressure
 ρ Density of the medium
 g Acceleration due to gravity
 p_{hydr} Hydrostatic pressure
 p_{atm} Atmospheric pressure
 p_{sens} Pressure displayed on the sensor

Temperature measurement

With optional Pt100 resistance thermometer¹⁾

For simultaneous measurement of level and temperature, Endress+Hauser offers the device with an optional 4-wire Pt100 resistance thermometer → 51. The Pt100 is categorized as Accuracy Class B as per DIN EN 60751.

With optional Pt100 and TMT71 temperature head transmitter

To convert the temperature signal to an analog, scalable 4 to 20 mA output signal, Endress+Hauser also offers the TMT71 temperature head transmitter.

Ordering information: → 49; "Accessories" → 51. Technical Information TI01393T.

With optional Pt100 and TMT72 temperature head transmitter¹⁾

Endress+Hauser also offers the TMT72 temperature head transmitter with HART protocol for converting the temperature signal to an analog, scalable 4 to 20 mA output signal superimposed with HART 6.0. See also: "Density compensation with Pt100 temperature sensor" → 12

Ordering information: → 49; "Accessories" → 51. Technical Information TI01392T.

1) Not for use in hazardous areas.

Measuring system

Application examples

As standard, the complete measuring system consists of a device and a transmitter power supply unit with a supply voltage of 10.5 to 30 V_{DC} (hazardous area) or 10.5 to 35 V_{DC} (non-hazardous area).

Possible measuring point solutions with a transmitter and evaluation units from Endress+Hauser:

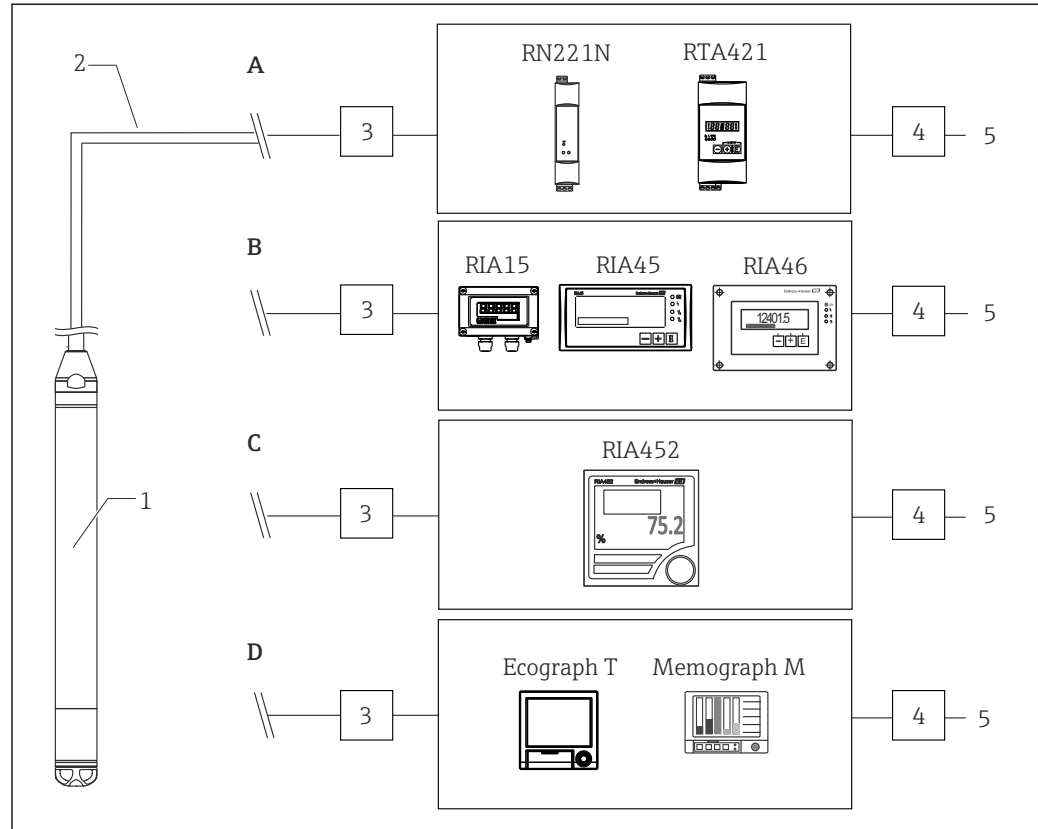

1 Device

2 4 to 20 mA or 4 to 20 mA HART

3+4 Overvoltage protection, e.g. HAW from Endress+Hauser (not for use in hazardous areas) HAW562; for DIN rail: HAW562/intrinsically safe HAW562Z. Selection in accordance with supply voltage.

5 Power supply

A: Easy and cost-effective measuring point solution: power supplied to the device in hazardous and non-hazardous areas via the RN221N active barrier. Power supply and additional control of two appliances, such as pumps, via the RTA421 limit value switch with local display.

B: The RIA45 evaluation unit (for panel mounting) or the RIA46 evaluation unit (for field installation) offers power supply, local display and two switch outputs. If the RIA15 is used, the basic settings for the HART device can be made via the display module.

C: If several pumps are used, the pump service life can be prolonged by alternate switching. With alternating pump control, the pump which was out of service for the longest period of time is switched on. The RIA452 evaluation unit (for panel mounting) offers this option in addition to numerous other functions.

D: State-of-the-art recording technology with graphic display recorders from Endress+Hauser, such as Ecograph T, Memograph M for documentation, monitoring, visualization and archiving purposes.

Application examples with the Pt100

As standard, the complete measuring system consists of a device and a transmitter power supply unit with a supply voltage of 10.5 to 30 V_{DC} (hazardous area) or 10.5 to 35 V_{DC} (non-hazardous area).

Possible measuring point solutions with a transmitter and evaluation units from Endress+Hauser:

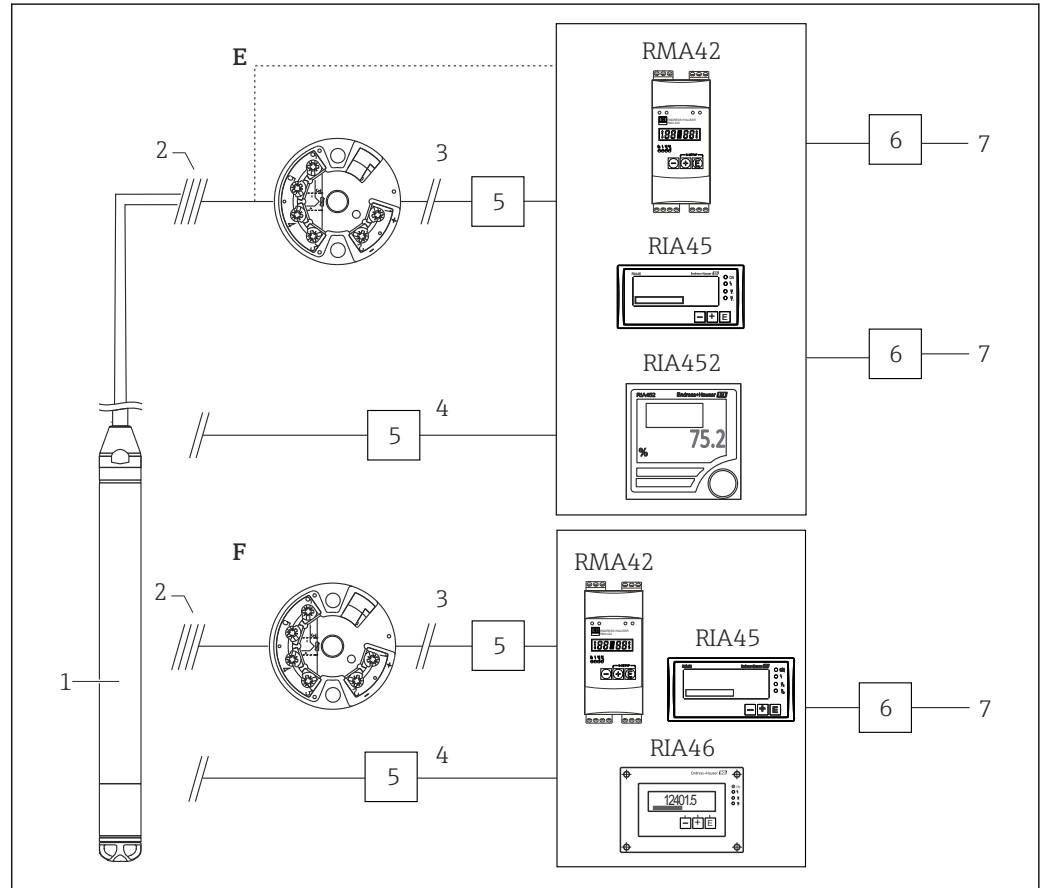

A0018645

- 1 Device
- 2 Connection for integrated Pt100 in the FMX21
- 3 Temperature for 4 to 20 mA or 4 to 20 mA HART
- 4 Level for 4 to 20 mA or 4 to 20 mA HART
- 5 Overvoltage protection, e.g. HAW from Endress+Hauser (not for use in hazardous areas) on the sensor side for field installation: HAW569; for DIN rail: HAW562/intrinsically safe HAW562Z. Selection in accordance with supply voltage.
- 6 Overvoltage protection, e.g. HAW from Endress+Hauser (not for use in hazardous areas) on the supply side for DIN rail: HAW561 (115/230 V) and HAW561K (24/48 V AC/DC). Selection in accordance with supply voltage.
- 7 Power supply

E: If you wish to measure, display and evaluate the temperature as well as the level, e.g. to monitor the temperature in fresh water for the purpose of detecting temperature limits for germ formation, the options available to you include the following: The optionally available TMT72 temperature head transmitter can convert the Pt100 signal to a 4 to 20 mA signal or a 4 to 20 mA HART signal and transfer it to any commonly used evaluation unit. The RMA42, RIA45 and RIA452 evaluation units also offer a direct input for the Pt100 signal.

F: If you wish to record and evaluate the level and temperature measured value with one device, use the RMA42, RIA45 and RIA46 evaluation units with two inputs. It is even possible to mathematically link the input signals with this unit. These evaluation units are HART-compatible.

Level measurement with absolute pressure probe and external pressure signal

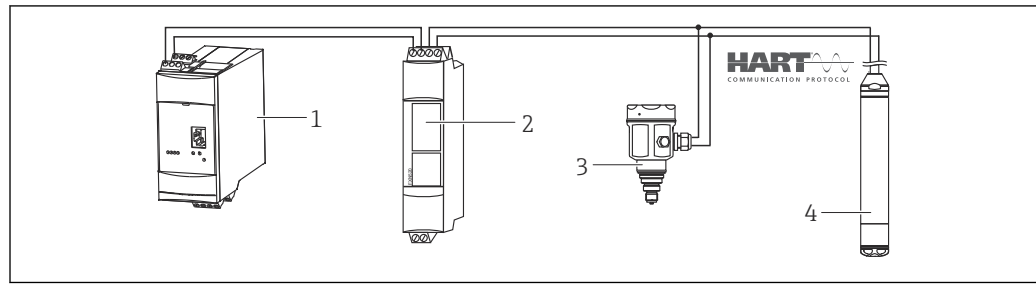

A0018757

- 1 Fieldgate FXA520
- 2 Multidrop Connector FXN520
- 3 Cerabar
- 4 Waterpilot 4 to 20 mA HART

It is advisable to use an absolute pressure probe for applications in which condensation can occur. For level measurement using an absolute pressure probe, the measured value is affected by fluctuations in the ambient pressure. To correct the resulting measured error, you can connect an external absolute pressure sensor (e.g. Cerabar) to the HART signal line, switch the Waterpilot to burst mode and operate the Cerabar in the "Electr. Delta P" mode. The external absolute pressure sensor then calculates the difference between the two pressure signals and can thus determine the level precisely. Only one level measured value can be corrected in this way.

i If using intrinsically safe devices, the regulations for interconnecting intrinsically safe circuits as stipulated in IEC60079-14 (proof of intrinsic safety) must be observed.

Density compensation with the Pt100 temperature sensor

The device can correct measured errors that result from fluctuations in the density of the water caused by temperature. Users can choose from the following options:

Use the internally measured sensor temperature of the device

The internally measured sensor temperature is calculated in the device for density compensation. The level signal is thus corrected according to the density characteristic line of water.

Use the optional internal temperature sensor for density compensation in a suitable HART master (e.g. PLC)

The device is available with an optional Pt100 temperature sensor. To convert the Pt100 signal to a 4 to 20 mA HART signal, Endress+Hauser also offers the TMT72 temperature head transmitter.

The temperature and pressure signals are queried by a HART master (e.g. PLC), where a corrected level value can be generated using a stored linearization table or density function (of a chosen medium).

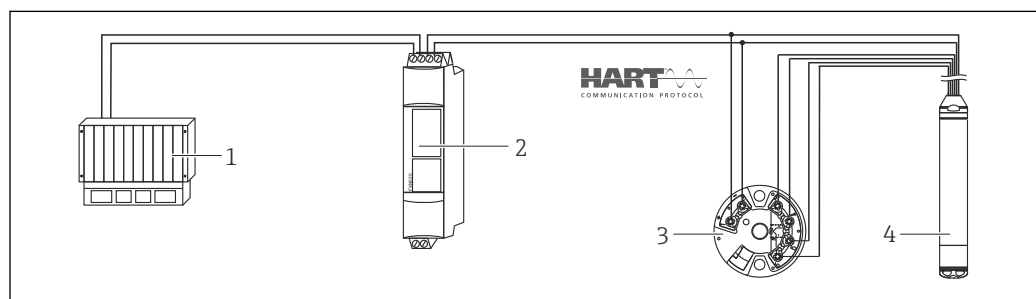

A0018763

- 1 HART master, e.g. PLC (programmable logic controller)
- 2 FXN520 Multidrop Connector
- 3 TMT72 temperature head transmitter
- 4 Waterpilot FMX2 1 4 to 20 mA HART

Use an external temperature signal which is transmitted to the device via the HART burst mode

The device is available with an optional Pt100 temperature sensor. With this option, the signal of the Pt100 is evaluated with a HART-compliant temperature transmitter (min. HART 5.0) that supports the BURST mode. The temperature signal can be transmitted to the device in this way. The device uses this signal for density correction of the level signal.

i The TMT72 temperature head transmitter is not suitable for this configuration.

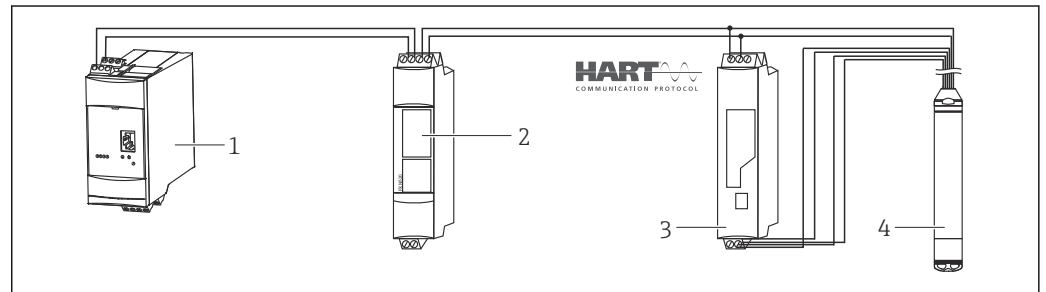

A0018764

- 1 Fieldgate FXA520
- 2 Multidrop Connector FXN520
- 3 HART-compatible temperature transmitter with burst function (e.g. TMT82)
- 4 Waterpilot FMX21 4 to 20 mA HART

Without additional compensation due to the anomaly of water, errors of up to 4 % may occur at a temperature of +70 °C (+158 °F), for example. With density compensation, this error is less than 0.5 % in the entire temperature range from 0 to +70 °C (+32 to +158 °F).

i More information can be found in the Technical Information:

- TI01010T: TMT82 temperature transmitter (4 to 20 mA HART)
- TI00369F: Fieldgate FXA520
- TI00400F: Multidrop Connector FXN520

Communication protocol

- 4 to 20 mA analog
- 4 to 20 mA HART

System integration The device can be given a tag name.

Input

Measured variable	FMX21 + Pt100 (optional) <ul style="list-style-type: none"> ■ Hydrostatic pressure of a liquid ■ Pt100: Temperature TMT71 temperature head transmitter (optional) Temperature
	TMT72 temperature head transmitter (optional) Temperature

Measuring range	<ul style="list-style-type: none"> ■ Customer-specific measuring ranges or calibration that has been preset in the factory ■ Temperature measurement of -10 to +70 °C (+14 to +158 °F) with Pt100 (optional)
------------------------	--

Gauge pressure

Sensor measuring range	Lowest calibratable span ¹⁾	Vacuum resistance	Option ²⁾
0.1 bar (1.5 psi)	0.01 bar (0.15 psi)	0.3 bar _{abs} (4.5 psi _{abs})	1C
0.2 bar (3.0 psi)	0.02 bar (0.3 psi)	0.3 bar _{abs} (4.5 psi _{abs})	1D
0.4 bar (6.0 psi)	0.04 bar (1.0 psi)	0 bar _{abs} (0 psi _{abs})	1F
0.6 bar (9.0 psi)	0.06 bar (1.0 psi)	0 bar _{abs} (0 psi _{abs})	1G
1.0 bar (15.0 psi)	0.1 bar (1.5 psi)	0 bar _{abs} (0 psi _{abs})	1H
2.0 bar (30.0 psi)	0.2 bar (3.0 psi)	0 bar _{abs} (0 psi _{abs})	1K
4.0 bar (60.0 psi)	0.4 bar (6.0 psi)	0 bar _{abs} (0 psi _{abs})	1M
10.0 bar (150 psi) ³⁾	1.0 bar (15.0 psi)	0 bar _{abs} (0 psi _{abs})	1P
20.0 bar (300 psi) ³⁾	2.0 bar (30.0 psi)	0 bar _{abs} (0 psi _{abs})	1Q

- 1) Largest turn down that can be configured at the factory: 10:1, higher turn down can be configured on request or in the device (for FMX21 4 to 20 mA HART).
- 2) Product Configurator order code for "070"
- 3) These measuring ranges are not available for the probe version with plastic insulation, outer diameter of 29 mm (1.14 in).

Absolute pressure

Sensor measuring range	Lowest calibratable span ¹⁾	Vacuum resistance	Option ²⁾
2.0 bar (30.0 psi)	0.2 bar (3.0 psi)	0 bar _{abs} (0 psi _{abs})	2K
4.0 bar (60.0 psi)	0.4 bar (6.0 psi)	0 bar _{abs} (0 psi _{abs})	2M
10.0 bar (150 psi) ³⁾	1.0 bar (15.0 psi)	0 bar _{abs} (0 psi _{abs})	2P
20.0 bar (300 psi) ³⁾	2.0 bar (30.0 psi)	0 bar _{abs} (0 psi _{abs})	2Q

- 1) Largest turn down that can be configured at the factory: 10:1, higher turn down can be configured on request or in the device (for FMX21 4 to 20 mA HART).
- 2) Product Configurator order code for "070"
- 3) These measuring ranges are not available for the probe version with plastic insulation, outer diameter of 29 mm (1.14 in).

Input signal

FMX21 + Pt100 (optional)

- Change in capacitance
- Pt100: Change in resistance

TMT71 temperature head transmitter (optional)

Pt100 resistance signal, 4 wire

TMT72 temperature head transmitter (optional)

Pt100 resistance signal, 4 wire

Output

Output signal

Device + Pt100 (optional)

- 4 to 20 mA Analog, 2-wire for hydrostatic pressure measured value.
 - 4 to 20 mA HART with superimposed digital communication protocol HART 6.0, 2-wire for hydrostatic pressure measured value.
- Options:
- Max. alarm (factory setting 22 mA): can be set from 21 to 23 mA
 - Hold measured value: last measured value is held
 - Min. alarm: 3.6 mA
- Pt100: temperature-dependent resistance value

TMT71 temperature head transmitter (optional)

4 to 20 mA analog for temperature measured value, 2-wire

TMT72 temperature head transmitter (optional)

4 to 20 mA HART with superimposed digital communication protocol HART 5.0 for temperature measured value, 2-wire

Signal range

3.8 to 20.5 mA

Maximum load

The maximum load resistance depends on the supply voltage (U) and must be determined individually for each current loop, see formula and diagrams for the device and temperature head transmitter. The total resistance resulting from the resistances of the connected devices, the connecting cable and, where applicable, the resistance of the extension cable may not exceed the load resistance value.

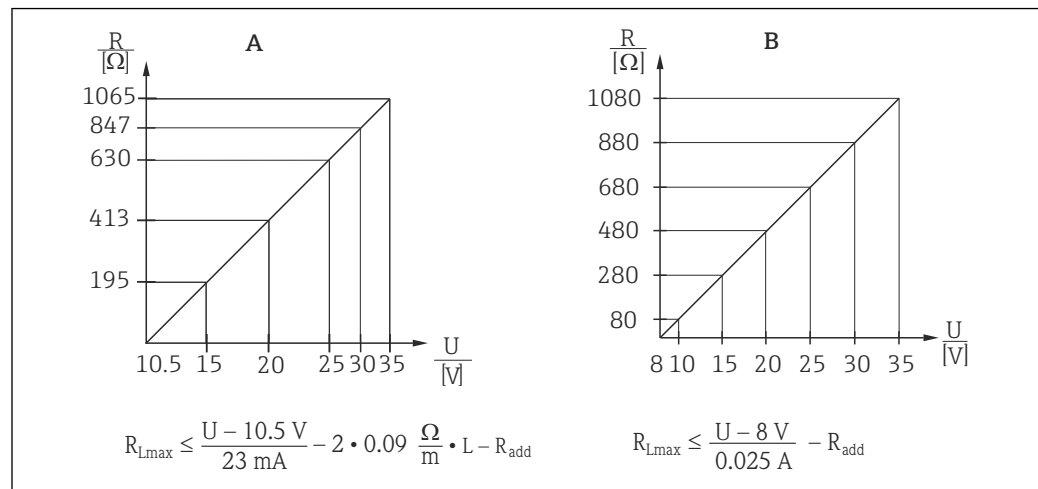

A Load diagram for device 4 to 20 mA analog for an approximate calculation of the load resistance. Additional resistances, such as the resistance of the extension cable, have to be subtracted from the value calculated as shown in the equation.

B Load diagram for TMT71 temperature head transmitter for estimating the load resistance. Additional resistances must be subtracted from the value calculated as shown in the equation

R_{Lmax} Max. load resistance [Ω]

R_{add} Additional resistances such as resistance of evaluating device and/or display unit, cable resistance [Ω]

U Supply voltage [V]

L Basic length of extension cable [m] (cable resistance per wire $\leq 0.09 \Omega/\text{m}$)

i When using the measuring device in hazardous areas, installation must comply with the corresponding national standards and regulations and the Safety Instructions or Installation or Control Drawings (XA).

Maximum load

The maximum load resistance depends on the supply voltage (U) and must be determined individually for each current loop, see formula and diagrams for the device and temperature head transmitter. The total resistance resulting from the resistances of the connected devices, the

connecting cable and, where applicable, the resistance of the extension cable may not exceed the load resistance value.

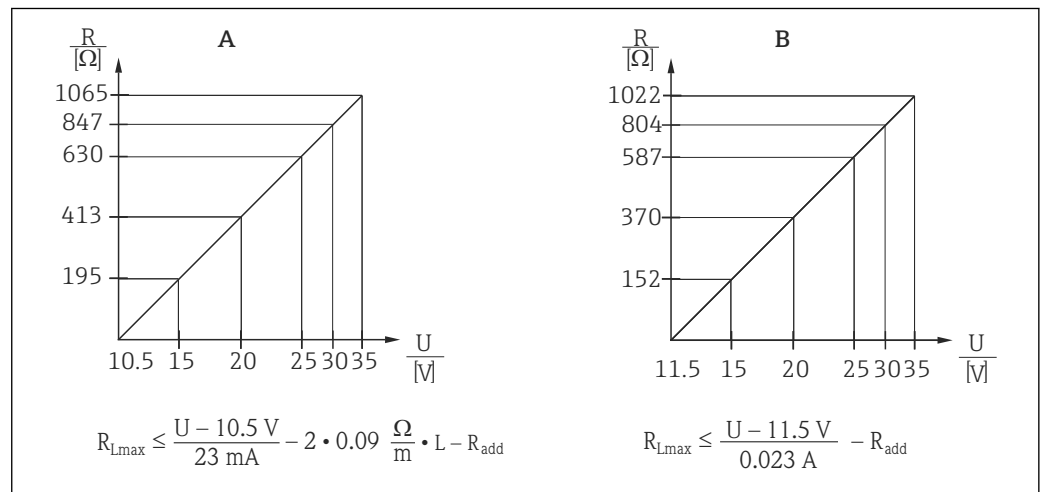

- A Load diagram for device 4 to 20 mA HART for an approximate calculation of the load resistance. Additional resistances, such as the resistance of the extension cable, have to be subtracted from the value calculated as shown in the equation.
- B Load diagram for TMT72 temperature head transmitter for estimating the load resistance. Additional resistances must be subtracted from the value calculated as shown in the equation

R_{Lmax} Max. load resistance [Ω]

R_{add} Additional resistances such as resistance of evaluating device and/or display unit, cable resistance [Ω]

U Supply voltage [V]

L Basic length of extension cable [m] (cable resistance per wire $\leq 0.09 \Omega/m$)

- When using the measuring device in hazardous areas, installation must comply with the corresponding national standards and regulations and the Safety Instructions or Installation or Control Drawings (XA).
- When operating via a handheld terminal or via a PC with an operating program, a minimum communication resistance of 250 Ω must be taken into account.

Damping

- Via HART handheld terminal or PC with operating program: continuously 0 to 999 s
- Factory setting: 2 s

Protocol-specific data

- Manufacturer ID: 17 (11 hex)
- Device type ID: 25 (19 hex)
- Device revision: 01 (01 hex) - SW version 01.00.zz
- HART specification: 6
- DD revision: 01
- Device description files (DTM, DD):
 - www.endress.com
 - www.fieldcommgroup.org
- HART load: min. 250 Ω
- HART device variables. The dynamic variables SV, TV and QV may be assigned to any device variable:
 - Standard process values for SV, TV (second and third device variable) are dependent on the measuring mode: pressure, level
 - Standard process value for QV (fourth device variable) is the sensor temperature: temperature
 - Measured values for PV (first device variable) are dependent on the measuring mode: pressure, level, tank content
- Supported functions:
 - Burst mode
 - Additional transmitter status
 - Device locking
 - Alternative measuring modes
 - Catch variable
 - Long tag

Power supply

WARNING

Electrical safety is compromised by an incorrect connection!

- ▶ When using the measuring device in a hazardous area, the relevant national standards and guidelines as well as the Safety Instructions (XAs) or installation or control drawings (ZDs) must be adhered to. All data relating to explosion protection can be found in separate documentation which is available on request. This documentation is supplied with the devices as standard
→  55

Supply voltage

Device + Pt100 (optional)

- 10.5 to 35 V (non-hazardous area)
- 10.5 to 30 V (hazardous area)

TMT71 temperature head transmitter (optional)

8 to 35 V_{DC}

TMT72 temperature head transmitter (optional)

11.5 to 35 V_{DC}

Power consumption

Device + Pt100 (optional)

- ≤ 0.805 W at 35 V_{DC} (non-hazardous area)
- ≤ 0.690 W at 30 V_{DC} (hazardous area)

TMT71 temperature head transmitter (optional)

≤ 0.875 W at 35 V_{DC}

TMT72 temperature head transmitter (optional)

≤ 0.805 W at 35 V_{DC}

Current consumption

Device + Pt100 (optional)

Max. current consumption: ≤ 23 mA
Min. current consumption: ≥ 3.6 mA

TMT71 temperature head transmitter (optional)



- Max. current consumption: ≤ 25 mA
- Min. current consumption: ≥ 3.5 mA

TMT72 temperature head transmitter (optional)

- Max. current consumption: ≤ 23 mA
- Min. current consumption: ≥ 3.5 mA

Connecting the device

- Reverse polarity protection is integrated in the device and the temperature head transmitter. Changing the polarities will not result in damage to the devices.
- The cable must end in a dry room or a suitable terminal box. The terminal box (IP66, IP67) with GORE-TEX® filter from Endress+Hauser is suitable for outdoor installation. The terminal box can be ordered as an accessory via the device order code.

The electrical connection is established with the corresponding wires of the probe cable and with the optional use of the terminal box →  36 and a power supply (e.g. RN22 1N active barrier →  10).

Device with Pt100

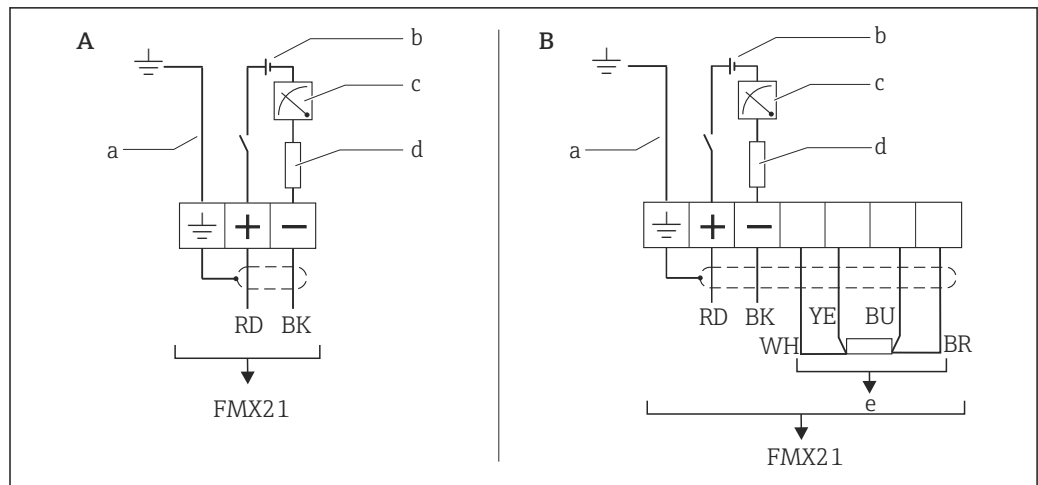

A0019441

- A Device
- B Device with Pt100 (not for use in hazardous areas)
- a Not for devices with external diameter of 29 mm (1.14 in)
- b 10.5 to 30 V_{DC} (hazardous area), 10.5 to 35 V_{DC}
- c 4 to 20 mA
- d Resistance (R_I)
- e Pt100

Device with Pt100 and TMT71 temperature head transmitter

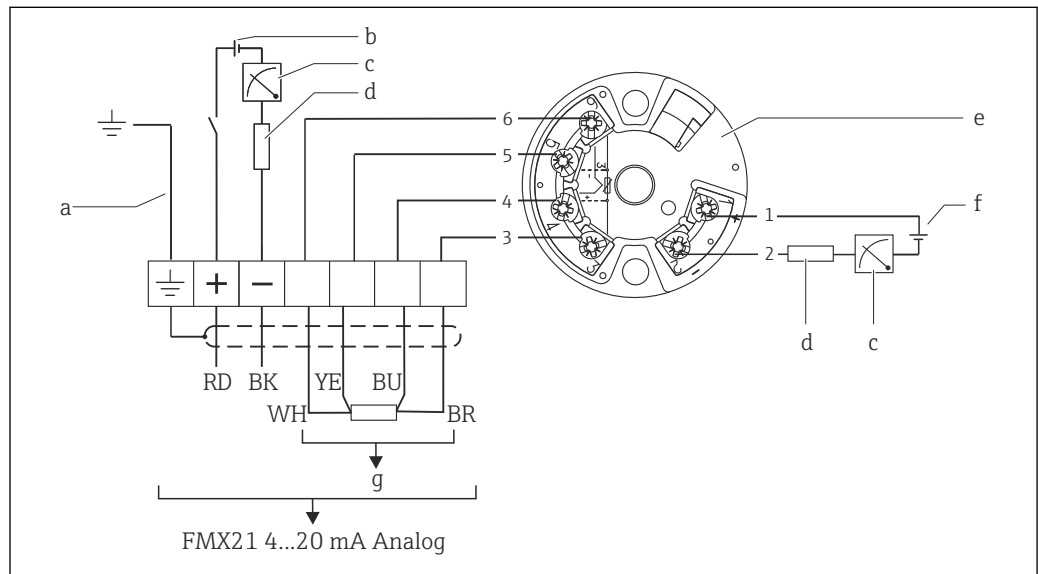

A0030945

- a Not for devices with external diameter of 29 mm (1.14 in)
- b 10.5 to 35 V_{DC}
- c 4 to 20 mA
- d Resistance (R_I)
- e TMT71 temperature head transmitter (4 to 20 mA) (not for use in hazardous areas)
- f 8 to 35 V_{DC}
- g Pt100
- 1 to Pin assignment
- 6

Device with Pt100 and TMT72 temperature head transmitter

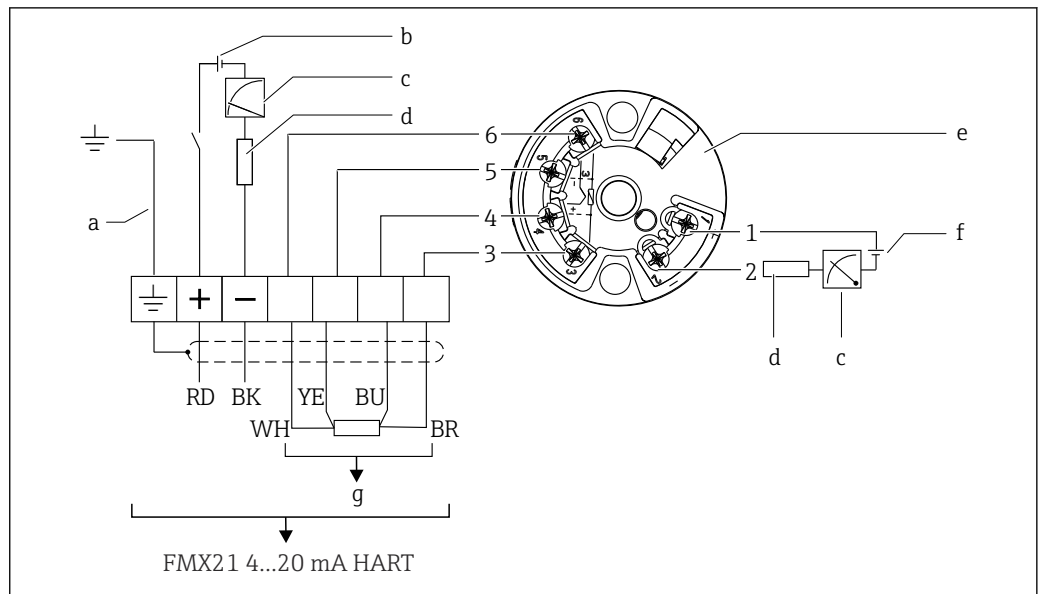

A0018780

- a Not for devices with external diameter of 29 mm (1.14 in)
- b 10.5 to 35 V_{DC}
- c 4 to 20 mA
- d Resistance (R_L)
- e TMT72 temperature head transmitter (4 to 20 mA) (not for use in hazardous areas)
- f 11.5 to 35 V_{DC}
- g Pt100
- 1 to Pin assignment
- 6

Device with RIA15

i The RIA15 remote display (for Ex or non-Ex area) can be ordered together with the device. See the Product Configurator.

Compensation of the atmospheric pressure must be ensured for the installation. A black, vented cable gland is supplied for this purpose.

i The RIA15 process indicator is loop-powered and does not require any external power supply.

The voltage drop to be taken into account is:

- ≤ 1 V in the standard version with 4 to 20 mA communication
- ≤ 1.9 V with HART communication
- and an additional 2.9 V if display light is used

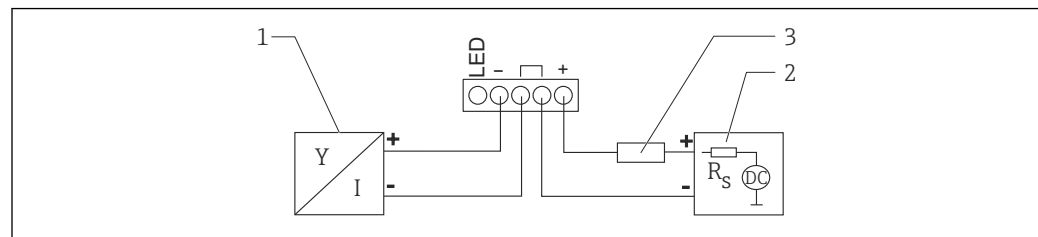
Without backlighting

A0019567

1 Block diagram; connection of the device with HART communication and RIA15 without backlighting

- 1 Device
- 2 Power supply
- 3 HART resistor

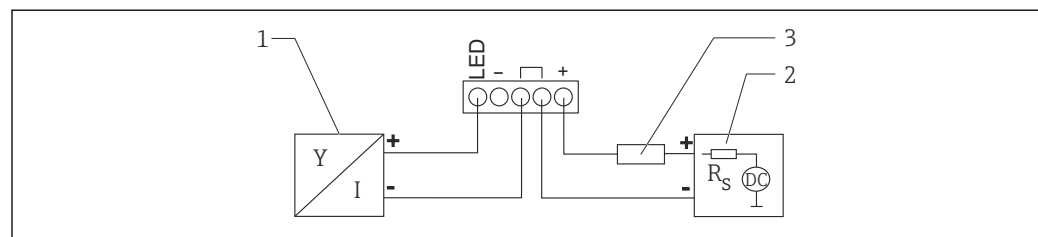
With backlighting

A0019568

2 Block diagram; connection of the device with HART communication and RIA15 with backlighting

- 1 Device
- 2 Power supply
- 3 HART resistor

Device, RIA15 with installed HART communication resistor module

 The HART communication module for installation in the RIA15 (for Ex or non-Ex areas) can be ordered together with the device.

The **voltage drop** to be taken into account is max. **7 V**

 Compensation of the atmospheric pressure must be ensured for the installation. A black, vented cable gland is supplied for this purpose.

Without backlighting

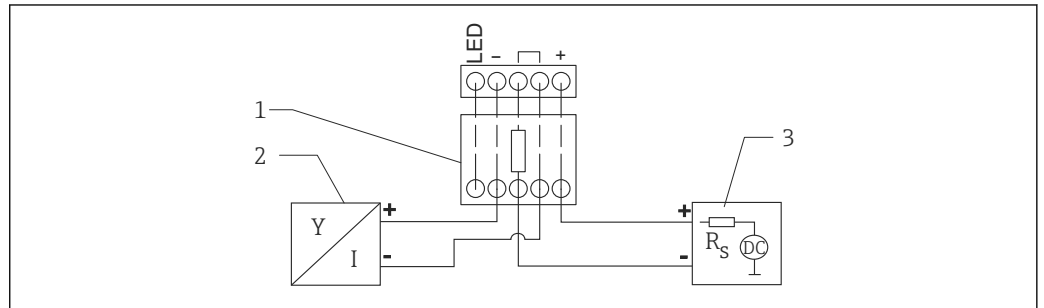

A0020839

 3 Block diagram; device connection, RIA15 without light, HART communication resistor

- 1 HART communication resistor module
- 2 Device
- 3 Power supply

With backlighting

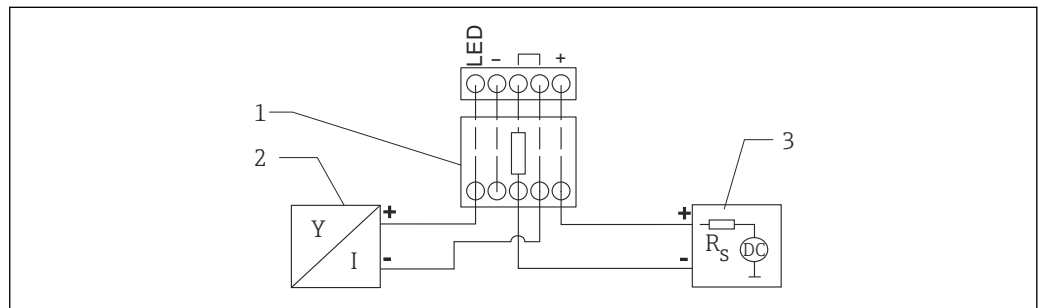

A0020840

 4 Block diagram; device connection, RIA15 with light, HART communication resistor module

- 1 HART communication resistor module
- 2 Device
- 3 Power supply

Wire colors

RD = red, BK = black, WH = white, YE = yellow, BU = blue, BR = brown



Connection data

Connection classification as per IEC 61010-1:

- Overvoltage category 1
- Pollution level 1

Connection data in the hazardous area

See relevant XA.

Terminals in the terminal box	<ul style="list-style-type: none"> ▪ Three terminals as standard in the terminal box (terminal box can optionally be ordered as an enclosed accessory → 51) ▪ 4-terminal strip can be ordered as an accessory, order number: 52008938 cable cross-section 0.08 to 2.5 mm² (28 to 14 AWG) <p> The 4-terminal strip is not designed for use in hazardous areas incl. CSA GP.</p>
Probe cable	<ul style="list-style-type: none"> ▪ Overall external diameter: 8 mm (0.31 in)±0.25 mm (0.01 in) ▪ Pressure compensation tube with Teflon filter: External diameter of 2.5 mm (0.1 in), internal diameter of 1.5 mm (0.06 in) <p>Cross-section</p> <ul style="list-style-type: none"> ▪ Device: 3 x 0.2 mm² (3 x 26 AWG) + pressure compensation tube with Teflon filter ▪ Device with Pt100 (optional): 7 x 0.2 mm² (7 x 26 AWG) + pressure compensation tube with Teflon filter
Cable resistance	Per wire: ≤ 0.09 Ω/m
Cable specifications	<p>Endress+Hauser recommends using shielded, twisted-pair two-wire cables.</p> <p> The probe cables are shielded for device versions with outer diameters of 22 mm (0.87 in) and 42 mm (1.65 in).</p> <p>Device + Pt100 (optional)</p> <ul style="list-style-type: none"> ▪ Commercially available instrument cable ▪ Terminals, terminal box: 0.08 to 2.5 mm² (28 to 14 AWG) <p>TMT71 temperature head transmitter (optional)</p> <ul style="list-style-type: none"> ▪ Commercially available instrument cable ▪ Terminals, terminal box: 0.08 to 2.5 mm² (28 to 14 AWG) ▪ Transmitter connection: max. 1.75 mm² (15 AWG) <p>TMT72 temperature head transmitter (optional)</p> <ul style="list-style-type: none"> ▪ Commercially available instrument cable ▪ Terminals, terminal box: 0.08 to 2.5 mm² (28 to 14 AWG) ▪ Transmitter connection: max. 1.75 mm² (15 AWG)
Residual ripple	<p>Device + Pt100 (optional)</p> <p>No impact on the 4 to 20 mA signal to ±5 % residual ripple within the permitted voltage range.</p> <p>TMT71 temperature head transmitter (optional)</p> <p>$U_{ss} \geq 5 \text{ V}$ at $U \geq 13 \text{ V}$, $f_{max.} = 1 \text{ kHz}$</p>
Residual ripple	<p>Device + Pt100 (optional)</p> <p>No impact on the 4 to 20 mA signal to ±5 % residual ripple within the permitted voltage range (according to HART Hardware Specification HCF_SPEC-54 (DIN IEC 60381-1)).</p> <p>TMT72 temperature head transmitter (optional)</p> <p>$U_{ss} \geq 3 \text{ V}$ at $U \geq 13 \text{ V}$, $f_{max.} = 1 \text{ kHz}$</p>

Performance characteristics

Reference operating conditions

Device + Pt100 (optional)

- As per IEC 60770
- Ambient temperature T_A = constant, in the range of: +21 to +33 °C (+70 to +91 °F)
- Humidity φ = constant, in the range of: 20 to 80 % rH
- Atmospheric pressure p_A = constant, in the range of: 860 to 1060 mbar (12.47 to 15.37 psi)
- Position of the measuring cell constant, vertical in the range of $\pm 1^\circ$
- Input of LOW SENSOR TRIM and HIGH SENSOR TRIM for lower range value and upper range value (only for HART)
- Supply voltage constant: 21 to 27 V_{DC}
- Load: 250 Ω
- Pt100: DIN EN 60770, T_A = +25 °C (+77 °F)

TMT71 temperature head transmitter (optional)

Calibration temperature: +23 °C (+73 °F) ± 5 K

TMT72 temperature head transmitter (optional)

Calibration temperature: +25 °C (+77 °F) ± 5 K

Reference accuracy

Device + Pt100 (optional)

The reference accuracy comprises the non-linearity after limit point configuration, hysteresis and non-reproducibility in accordance IEC 60770.

Standard version:

Setting ± 0.2 %

- to TD 5:1: < 0.2 % of set span
- from TD 5:1 to TD 20:1 $\pm (0.02 \times TD + 0.1)$

Platinum version:

- Setting ± 0.1 % (optional)
 - to TD 5:1: < 0.1 % of set span
 - from TD 5:1 to TD 20:1 $\pm (0.02 \times TD)$
- Class B as per DIN EN 60751
Pt100: max. ± 1 K

TMT71 temperature head transmitter (optional)

- ± 0.2 K
- With Pt100: max. ± 0.9 K

TMT72 temperature head transmitter (optional)

- ± 0.2 K
- With Pt100: max. ± 0.9 K

Resolution

Current output: 1 μ A

Reading cycle

HART commands: on average 2 to 3 per second

Long-term stability	Device + Pt100 (optional) <ul style="list-style-type: none">▪ ≤ 0.1 % of URL/year▪ ≤ 0.25 % of URL/5 years TMT71 temperature head transmitter (optional) <p>≤ 0.1 K per year</p> TMT72 temperature head transmitter (optional) <p>≤ 0.1 K per year</p>
Influence of medium temperature	<ul style="list-style-type: none">▪ Thermal change in the zero output and the output span:<ul style="list-style-type: none">0 to 30 °C (+32 to 86 °F): $< (0.15 + 0.15 \times TD)\%$ of set span-10 to +70 °C (+14 to 158 °F): $< (0.4 + 0.4 \times TD)\%$ of set span▪ Temperature coefficient (T_K) of the zero output and the output span<ul style="list-style-type: none">-10 to +70 °C (+14 to 158 °F): 0.1 % / 10 K of URL
Warm-up time	Device + Pt100 (optional) <ul style="list-style-type: none">▪ Device: < 6 s▪ Pt100: 300 s TMT71 temperature head transmitter (optional) <p>4 s</p> TMT72 temperature head transmitter (optional) <p>4 s</p>
Response time	Device + Pt100 (optional) <ul style="list-style-type: none">▪ Device: 400 ms (T90 time), 500 ms (T99 time)▪ Pt100: 160 s (T90 time), 300 s (T99 time)

Mounting

Installation instructions

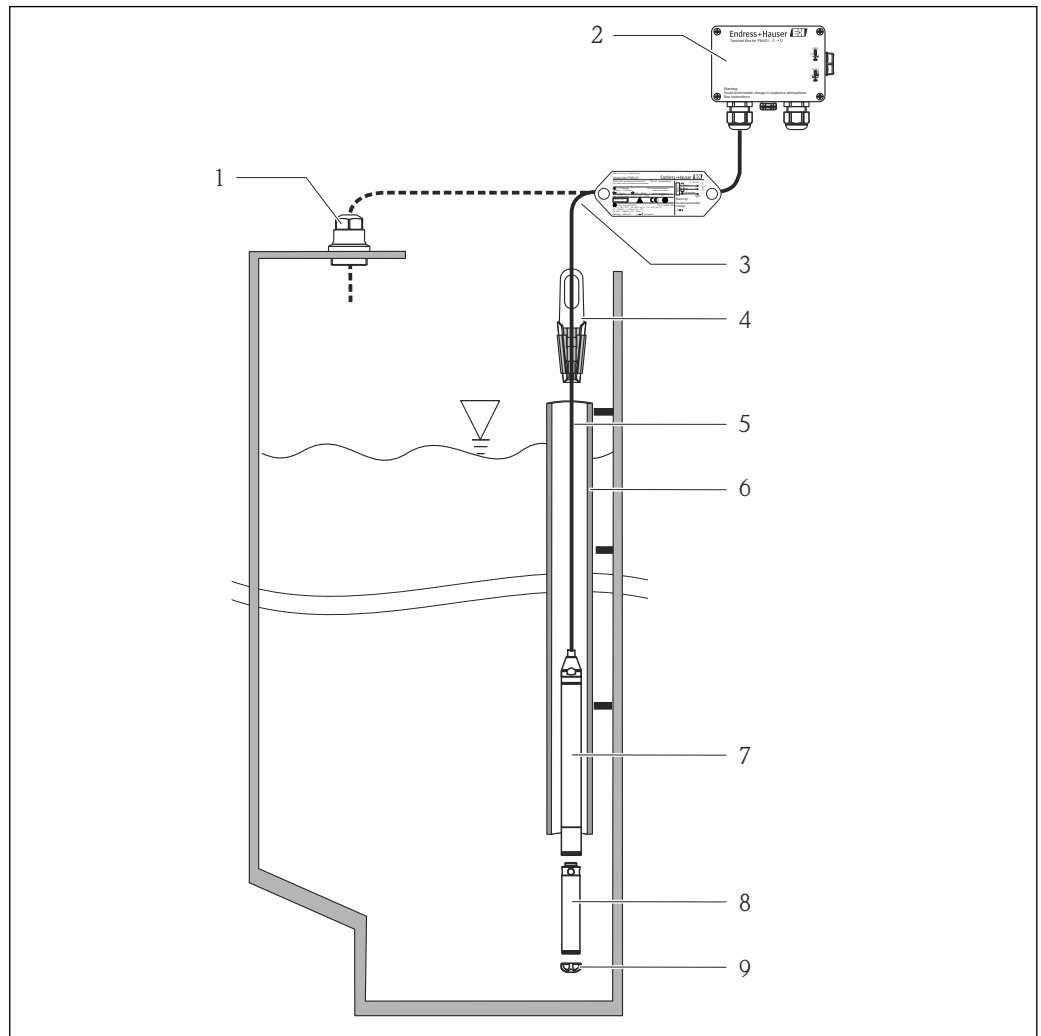

A0018770

- 1 Cable mounting screw can be ordered via the order code or as an accessory → 51
- 2 Terminal box can be ordered via the order code or as an accessory → 51
- 3 Bending radius of extension cable 120 mm (4.72 in)
- 4 Suspension clamp can be ordered via the order code or as an accessory → 51
- 5 Extension cable, cable length → 28
- 6 Guide tube
- 7 Device
- 8 Additional weight can be ordered as an accessory for the device with external diameter of 22 mm (0.87 in) and 29 mm (1.14 in) → 51
- 9 Protective cap

Additional installation instructions

- Sideways movement of the level probe can result in measuring errors. For this reason, install the probe at a point free from flow and turbulence, or use a guide tube. The internal diameter of the guide tube should be at least 1 mm (0.04 in) greater than the external diameter of the selected FMX21.
- To avoid mechanical damage to the measuring cell, the device is equipped with a protection cap.
- The cable must end in a dry room or a suitable terminal box. The terminal box from Endress +Hauser provides humidity and climatic protection and is suitable for installation outdoors → 51.
- Cable length tolerance: < 5 m (16 ft): ±17.5 mm (0.69 in); > 5 m (16 ft): ±0.2 %
- If the cable is shortened, the filter at the pressure compensation tube must be reattached. Endress +Hauser offers a cable shortening kit for this purpose → 51 (documentation SD00552P/00/A6).

- Endress+Hauser recommends using twisted, shielded cable.
- In shipbuilding applications, measures are required to restrict the spread of fire along cable looms.
- The length of the extension cable depends on the intended level zero point. The height of the protection cap must be taken into consideration when designing the layout of the measuring point. The level zero point (E) corresponds to the position of the process isolating diaphragm. Level zero point = E; tip of probe = L (see the following diagram).
For dimensions, see "Mechanical construction" section.

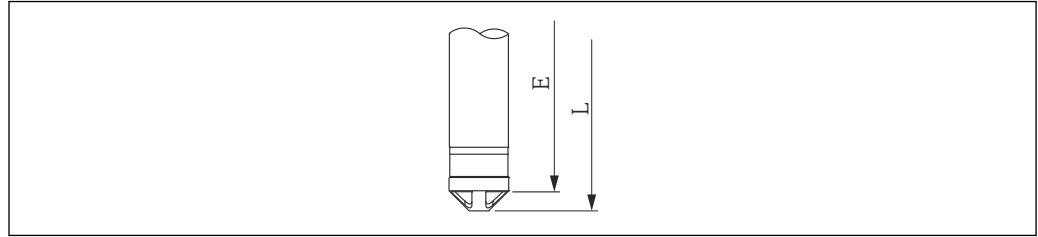

A0026013

Cable length

- Pay attention to the "Load"
- Cable lengths available for order
 - Customer-specific in meters or feet
 - Limited cable length when performing installation with freely suspended device with cable mounting screw or suspension clamp, as well as for Ex approval: max. 300 m (984 ft).
- **i** When using the measuring device in hazardous areas, installation must also comply with the applicable national standards and regulations and the Safety Instructions or Installation or Control Drawings.

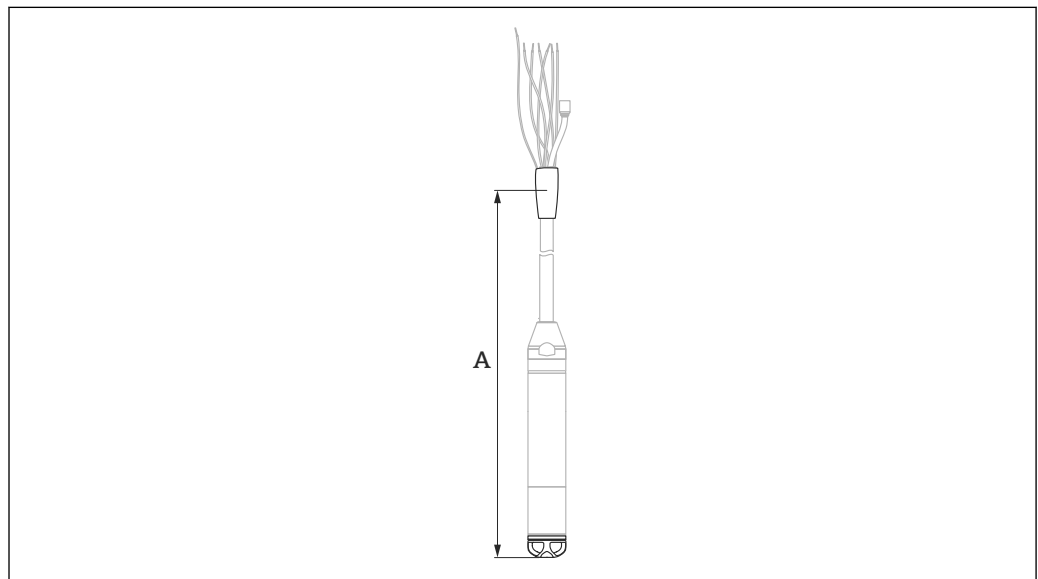

A0020556

A Length of extension cable

The following cable lengths can be selected in the Product Configurator:

- 10 m cable, can be shortened, PE
- 20 m cable, can be shortened, PE
- m cable, can be shortened, PE
- 30 ft cable, can be shortened, PE
- 60 ft cable, can be shortened, PE
- ft cable, can be shortened, PE
- 10 m cable, can be shortened, FEP
- 20 m cable, can be shortened, FEP
- m cable, can be shortened, FEP
- 30 ft cable, can be shortened, FEP
- 60 ft cable, can be shortened, FEP
- ft cable, can be shortened, FEP
- 10 m cable, can be shortened, PUR

- 20 m cable, can be shortened, PUR
- m cable, can be shortened, PUR
- 30 ft cable, can be shortened, PUR
- 60 ft cable, can be shortened, PUR
- ft cable, can be shortened, PUR

Technical data for cable

- Minimum bending radius: 120 mm (4.72 in)
- Tensile strength: max. 950 N (213.56 lbf)
- Cable extraction force (= tensile force required to extract the cable from the probe):
 - PE, FEP: typically ≥ 400 N (89.92 lbf), PUR: typically ≥ 150 N (33.72 lbf)
 - when used in hazardous area: ≥ 100 N (73.75 lbf)
- UV-resistant (UV = ultraviolet)
- PE: For use in drinking water

Cable marking

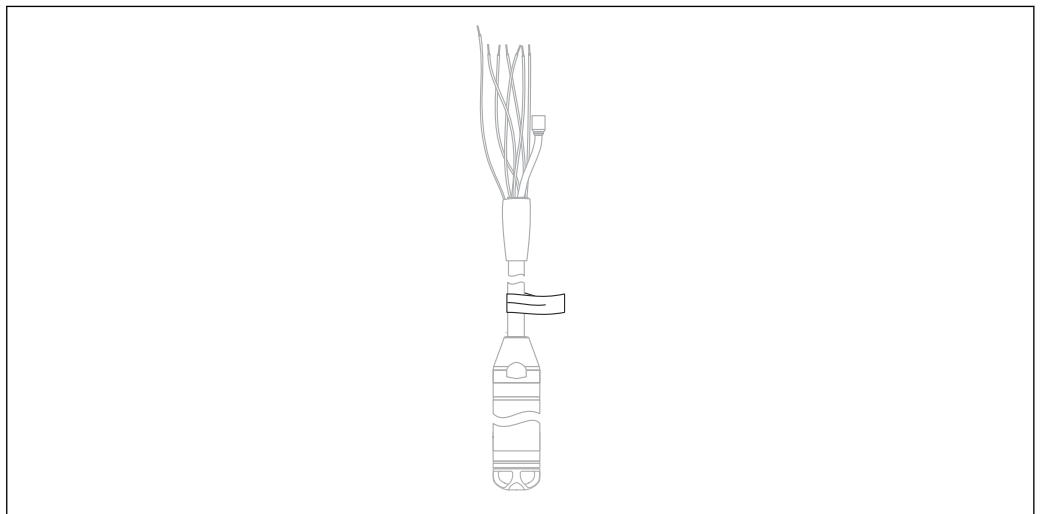

A0030955

- To make installation easier, Endress+Hauser marks the extension cable if a customer-specific length has been ordered.
- Cable marking tolerance (distance to lower end of level probe):
 - Cable length < 5 m (16 ft): ± 17.5 mm (0.69 in)
 - Cable length > 5 m (16 ft): ± 0.2 %
- Material: PET, stick-on label: acrylic
- Immunity to temperature change: -30 to $+100$ °C (-22 to $+212$ °F)

NOTICE

The marking is used exclusively for installation purposes.

- ▶ The mark must be thoroughly removed without trace in the case of devices with drinking water approval. The extension cable must not be damaged in the process.

 Not for the use of the device in hazardous areas.

Cable shortening kit

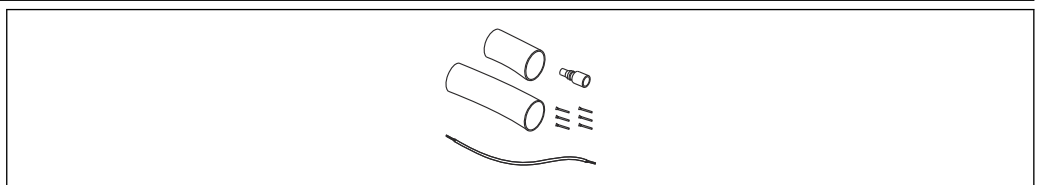



A0030948

The cable shortening kit is used to shorten a cable easily and professionally.

 The cable shortening kit is not designed for the device with FM/CSA approval.

- Ordering information: see Product Configurator
- Associated documentation SD00552P/00/A6.

Environment

Ambient temperature range	<p>Device + Pt100 (optional)</p> <ul style="list-style-type: none"> ■ With external diameter of 22 mm (0.87 in) and 42 mm (1.65 in): -10 to +70 °C (+14 to +158 °F) (= medium temperature) ■ With external diameter of 29 mm (1.14 in): 0 to +50 °C (+32 to +122 °F) (= medium temperature) <p>Cable</p> <p>(when mounted in a fixed position)</p> <ul style="list-style-type: none"> ■ With PE: -30 to +70 °C (-22 to +158 °F) ■ With FEP: -40 to +70 °C (-40 to +158 °F) ■ With PUR: -40 to +70 °C (-40 to +158 °F) <p>Terminal box</p> <p>-40 to +80 °C (-40 to +176 °F)</p> <p>TMT71 temperature head transmitter (optional)</p> <p>-40 to +85 °C (-40 to +185 °F)</p> <p>Temperature head transmitter 2-wire, configured for a measuring range of -20 to +80 °C (-4 to +176 °F). This configuration offers a temperature range of 100 K which can be easily mapped. Please note that the Pt100 resistance temperature detector is suitable for a temperature range of -10 to +70 °C (14 to +158 °F)</p> <p> The TMT71 temperature head transmitter is not designed for use in hazardous areas incl. CSA GP.</p> <p>TMT72 temperature head transmitter (optional)</p> <p>-40 to +85 °C (-40 to +185 °F)</p> <p>Temperature head transmitter 2-wire, configured for a measuring range of -20 to +80 °C (-4 to +176 °F). This configuration offers a temperature range of 100 K which can be easily mapped. Please note that the Pt100 resistance temperature detector is suitable for a temperature range of -10 to +70 °C (14 to +158 °F)</p> <p> The TMT72 temperature head transmitter is not designed for use in hazardous areas incl. CSA GP.</p>
Storage temperature range	<p>Device + Pt100 (optional)</p> <p>-40 to +80 °C (-40 to +176 °F)</p> <p>Cable</p> <p>(when mounted in a fixed position)</p> <ul style="list-style-type: none"> ■ With PE: -30 to +70 °C (-22 to +158 °F) ■ With FEP: -30 to +80 °C (-22 to +176 °F) ■ With PUR: -40 to +80 °C (-40 to +176 °F) <p>Terminal box</p> <p>-40 to +80 °C (-40 to +176 °F)</p> <p>TMT71 temperature head transmitter (optional)</p> <p>-40 to +100 °C (-40 to +212 °F)</p> <p>TMT72 temperature head transmitter (optional)</p> <p>-40 to +100 °C (-40 to +212 °F)</p>
Degree of protection	<p>Device + Pt100 (optional)</p> <p>IP68, permanently hermetically sealed at 20 bar (290 psi) (~200 m H₂O)</p>

Terminal box (optional)

IP66, IP67

TMT71 temperature head transmitter (optional)

IP00, condensation permitted

When installed in the optional terminal boxes: IP66/IP67

TMT72 temperature head transmitter (optional)

IP00, condensation permitted

Electromagnetic compatibility (EMC)

Device + Pt100 (optional)

- EMC in accordance with all relevant requirements of EN 61326 series. For details, refer to the Declaration of Conformity.
- Maximum deviation: < 0.5 % of span.

TMT71 temperature head transmitter (optional)

Interference emission to EN 61326 Class B equipment, interference immunity to EN 61326 Appendix A (Industrial). For details, refer to the Declaration of Conformity.

TMT72 temperature head transmitter (optional)

EMC in accordance with all relevant requirements of EN 61326 series. For details, refer to the Declaration of Conformity.

Overvoltage protection

FMX21 + Pt100 (optional)

- Integrated overvoltage protection as per EN 61000-4-5 (500 V symmetrical/1000 V asymmetrical)
- Provide overvoltage protection ≥ 1.0 kV, externally if necessary.

TMT71 temperature head transmitter (optional)

Provide overvoltage protection, externally if necessary →  10.

TMT72 temperature head transmitter (optional)

Provide overvoltage protection, externally if necessary →  10.

Process

Medium temperature range

Device + Pt100 (optional)

- With external diameter of 22 mm (0.87 in) and 42 mm (1.65 in):
-10 to +70 °C (+14 to +158 °F)
- With external diameter of 29 mm (1.14 in):
0 to +50 °C (+32 to +122 °F)

TMT71 temperature head transmitter (optional)

-40 to +85 °C (-40 to +185 °F)

(= ambient temperature), install temperature head transmitter outside the medium.

Temperature head transmitter 2-wire, configured for a measuring range of -20 to +70 °C (-4 to +158 °F). This configuration offers a temperature range of 100 K which can be easily mapped. Please note that the Pt100 resistance temperature detector is suitable for a temperature range of -10 to +70 °C (14 to +158 °F)

 The TMT71 temperature head transmitter is not designed for use in hazardous areas incl. CSA GP.

TMT72 temperature head transmitter (optional)

-40 to +85 °C (-40 to +185 °F)

(= ambient temperature), install temperature head transmitter outside the medium.

Temperature head transmitter 2-wire, configured for a measuring range of -20 to +80 °C (-4 to +176 °F). This configuration offers a temperature range of 100 K which can be easily mapped. Please note that the Pt100 resistance temperature detector is suitable for a temperature range of -10 to +70 °C (14 to +158 °F)

 The TMT72 temperature head transmitter is not designed for use in hazardous areas incl. CSA GP.

Medium temperature limit

Device + Pt100 (optional)

With external diameter of 22 mm (0.87 in) and 42 mm (1.65 in):
-20 to +70 °C (-4 to +158 °F)

 In hazardous areas incl. CSA GP, the medium temperature limit is -10 to +70 °C (+14 to +158 °F).

With external diameter of 29 mm (1.14 in): 0 to +50 °C (+32 to +122 °F)

 The FMX21 may be operated in this temperature range. The specification values, such as accuracy, may be exceeded.

Pressure specifications

WARNING

The maximum pressure for the measuring device depends on the lowest-rated element with regard to pressure.

- ▶ For pressure specifications, see the "Measuring range" section and the "Mechanical construction" section.
- ▶ The measuring device must be operated only within the specified limits!
- ▶ The Pressure Equipment Directive (2014/68/EU) uses the abbreviation "PS". The abbreviation "PS" corresponds to the MWP (maximum working pressure) of the measuring device.
- ▶ MWP (maximum working pressure): The MWP (maximum working pressure) is specified on the nameplate. This value refers to a reference temperature of +20 °C (+68 °F) and may be applied to the device for an unlimited time. Observe the temperature dependency of the MWP.
- ▶ OPL (Over Pressure Limit): The overpressure limit is the maximum pressure a device may be subjected to during a test. It is greater than the maximum working pressure by a certain factor. In the case of sensor range and process connection combinations where the over pressure limit (OPL) of the process connection is smaller than the nominal value of the sensor, the device is set at the factory, at the very maximum, to the OPL value of the process connection. If you want to use the entire sensor range, select a process connection with a higher OPL value.
- ▶ Avoid steam hammering! Steam hammering can cause zero point drift. Recommendation: Residue (such as condensation or drops of water) can remain on the process membrane after CIP cleaning and lead to local steam hammering if steam cleaning is performed again. In practice, drying the process membrane (e.g. by blowing off excess moisture) has proven to be a successful way of avoiding steam hammering.

Mechanical construction

Dimensions of the level probe

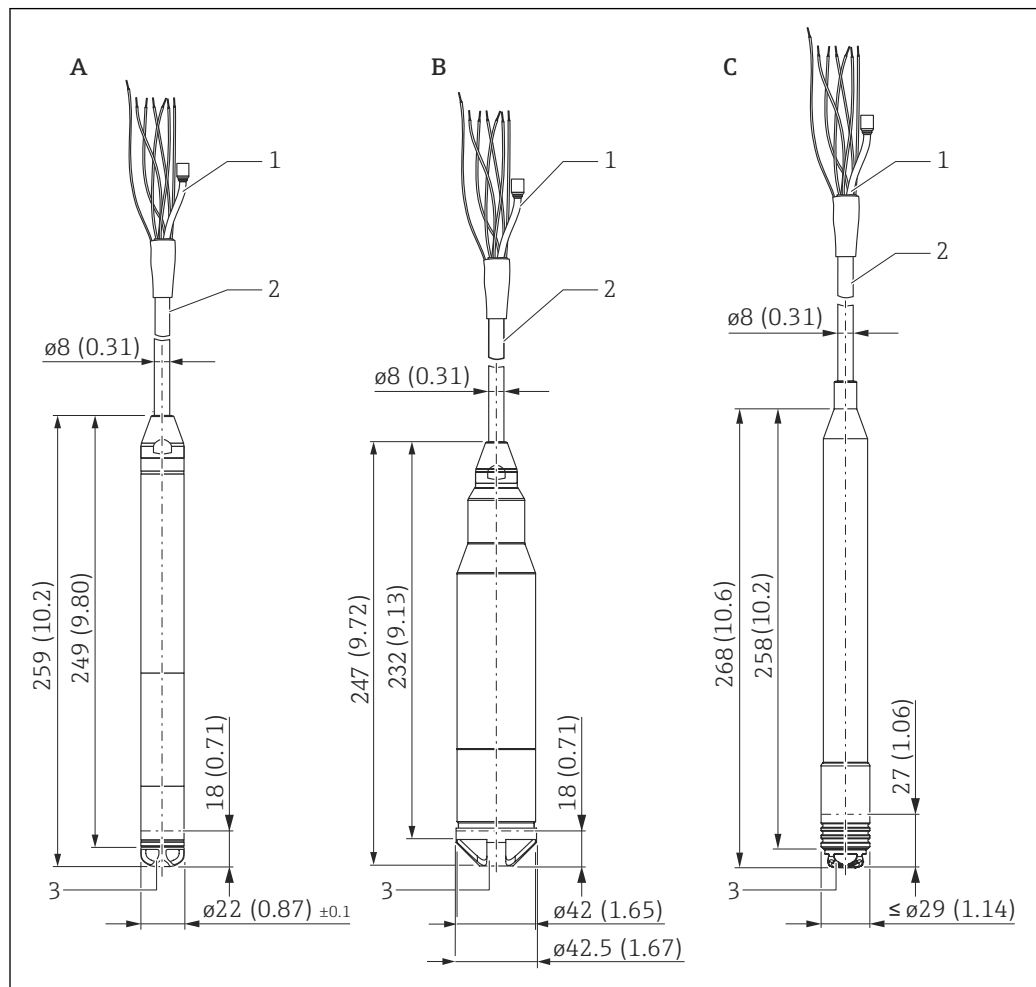

A0018771

Unit of measurement mm (in)

- A Probe tube; 316L, outer diameter 22 mm (0.87 in)
- B Probe tube; 316L, outer diameter 42 mm, flush mount
- C Probe tube; PPS/polyolefin > 316L, outer diameter 29 mm, saltwater applications
- 1 Pressure compensation tube
- 2 Extension cable (length, see → 28)
- 3 Protective cap

Dimensions of the suspension clamp

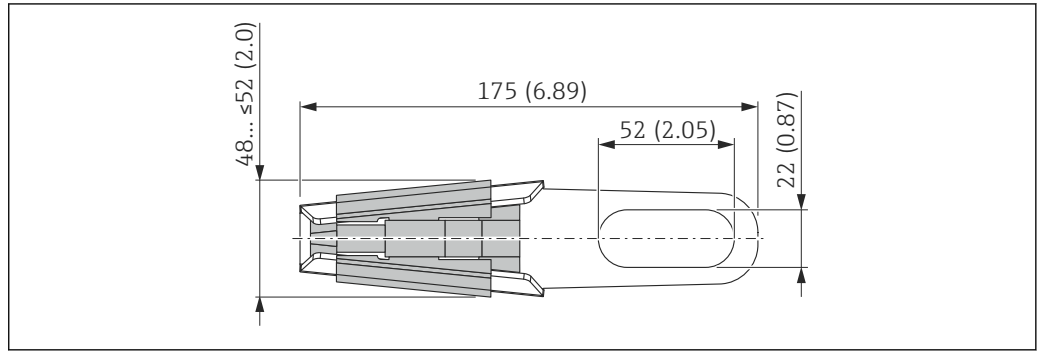

A0018659

Unit of measurement mm (in)

Product Configurator: the suspension clamp is optionally available. → 51

Dimensions of the cable mounting screw

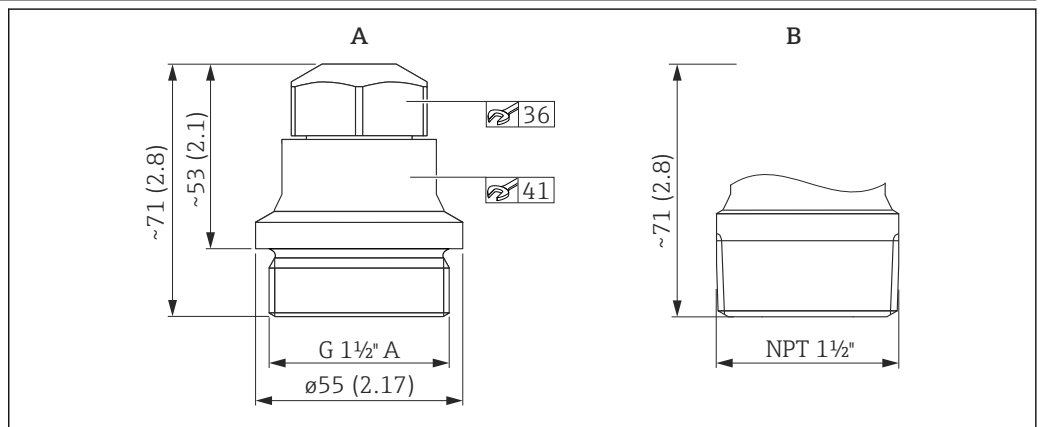

A0018661

Unit of measurement mm (in)

A G 1 1/2" A → 51

B NPT 1 1/2" → 51

- Use only in unpressurized vessels.
- Product Configurator: the cable mounting screw is optionally available.

Dimensions of terminal box IP66, IP67 with filter

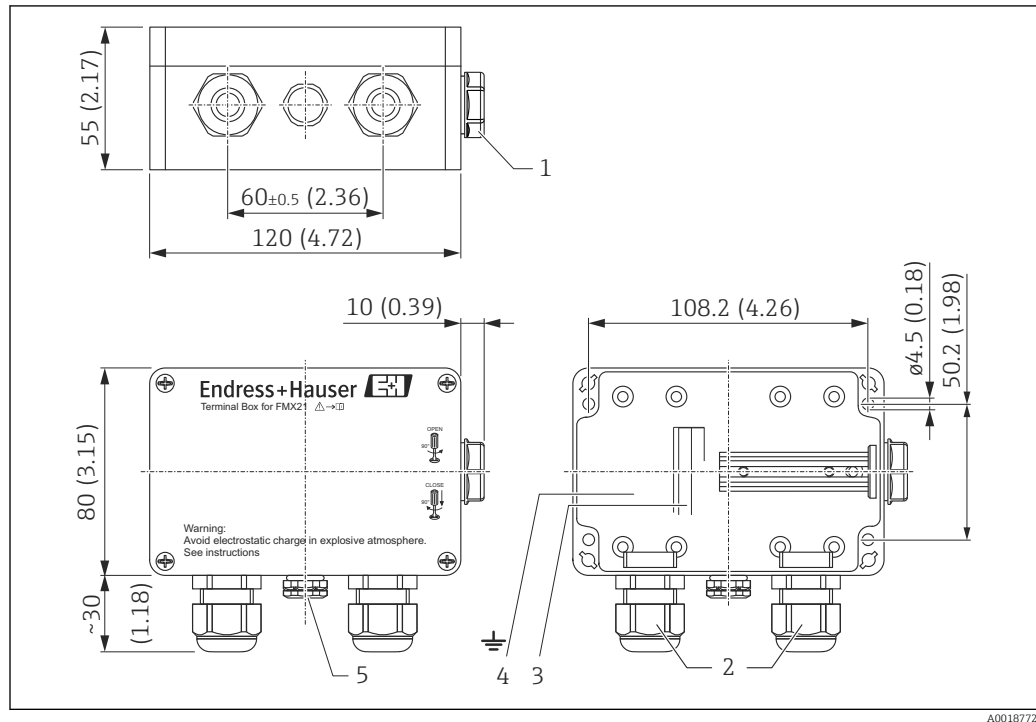

Unit of measurement mm (in)

- 1 Dummy plug M20x1.5
- 2 Cable gland M20x1.5
- 3 4 to 20 mA; terminals for 0.08 to 2.5 mm² (28 to 14 AWG) 0.08 to 2.5 mm²
- 4 Ground connection; terminals for 0.08 to 2.5 mm² (28 to 14 AWG) 0.08 to 2.5 mm²
- 5 GORE-TEX® filter

Terminal box IP66/IP67 with GORE-TEX® filter incl. 3 integrated terminals. The terminal box is also suitable for the installation of a temperature head transmitter or four other terminals

Ordering information:

- Product Configurator: the terminal box is optionally available. → 51
- TMT71: Product Configurator: the temperature head transmitter TMT71 is optionally available. → 51
- TMT72: Product Configurator: the temperature head transmitter TMT72 is optionally available. → 51

i The terminal box is not designed for the device with type of protection Ex nA in hazardous areas. If the terminal box is used in a hazardous area, the Safety Instructions of the relevant device must be observed, as well as the applicable regulations for explosion protection.

If the device with optional Pt100 is supplied, a terminal strip is provided with the terminal box for the purpose of wiring the Pt100.

i The 4-terminal strip is not designed for use in hazardous areas incl. CSA GP.

**Dimensions of the TMT71
temperature head
transmitter**

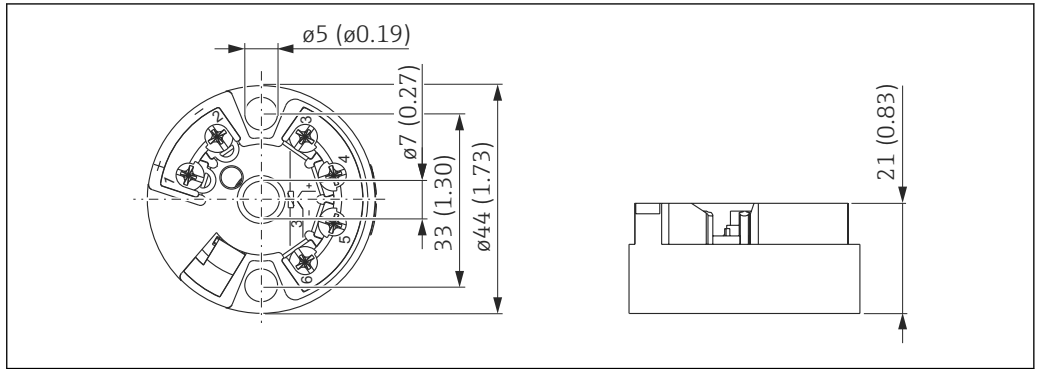

A0018775

Unit of measurement mm (in)

**Dimensions of the TMT72
temperature head
transmitter**

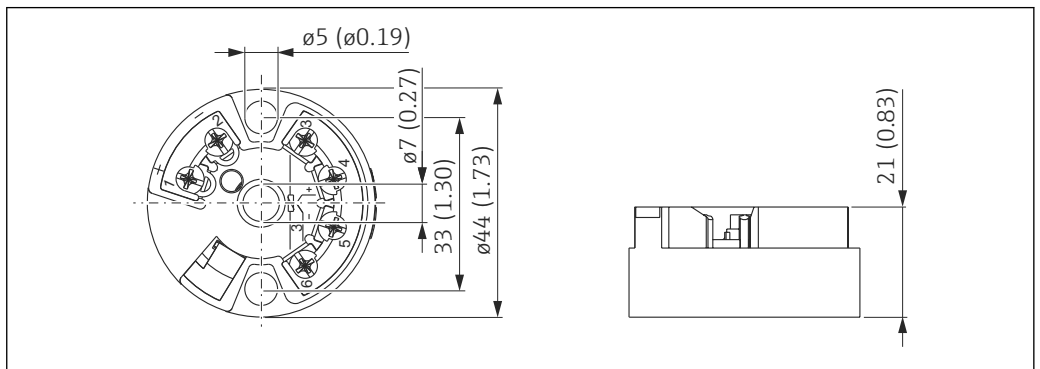

A0018775

Unit of measurement mm (in)

**Terminal box with integrated
TMT71 temperature head
transmitter**

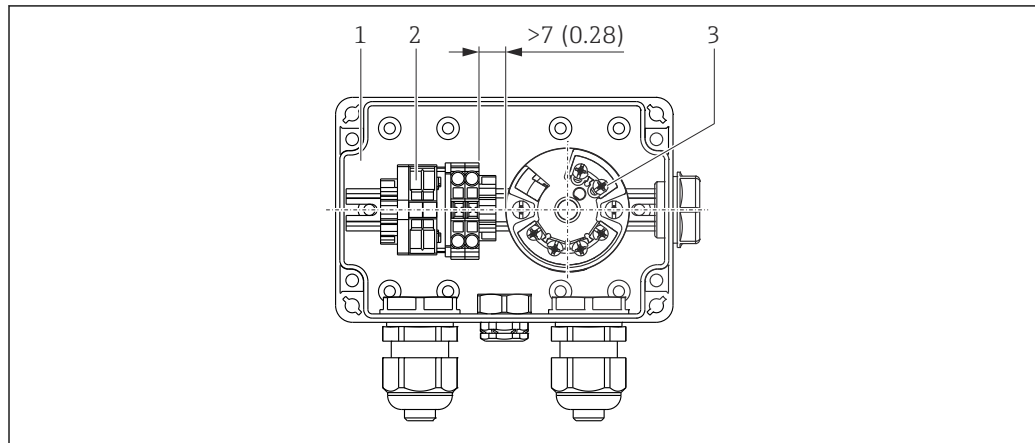

A0018696

Unit of measurement mm (in)

- 1 Terminal box
- 2 Terminal strip/terminals
- 3 TMT71 temperature head transmitter



A distance of > 7 mm (0.28 in) must be maintained between the terminal strip and the TMT71 temperature head transmitter.

**Terminal box with integrated
TMT72 temperature head
transmitter**

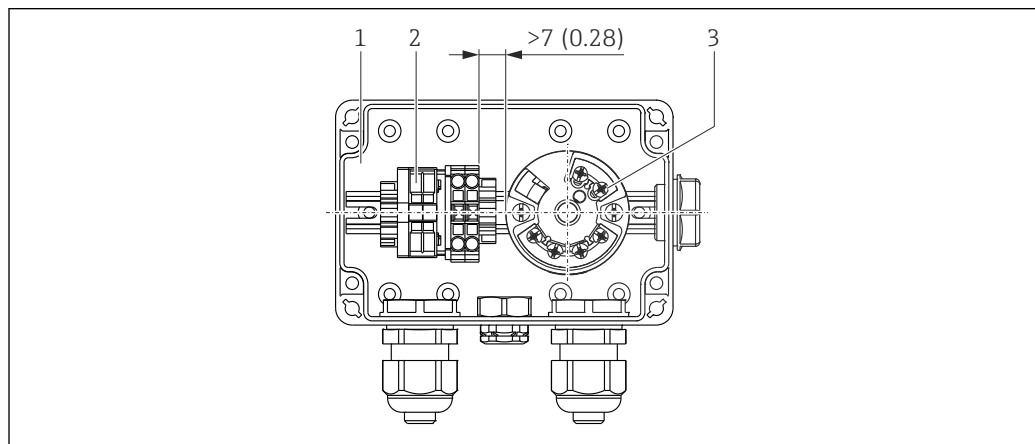

A0018696

Unit of measurement mm (in)

- 1 Terminal box
- 2 Terminal strip/terminals
- 3 TMT72 temperature head transmitter



A distance of > 7 mm (0.28 in) must be maintained between the terminal strip and the TMT72 temperature head transmitter.

Additional weight

For devices with external diameter of 22 mm (0.87 in) or 29 mm (1.14 in)

- Endress+Hauser offers additional weights to prevent sideways movement that results in measuring errors, or to make it easier to lower the device in a guide tube. You can screw several weights together. The weights are screwed directly onto the device. For devices with external diameter of 29 mm (1.14 in), a maximum of 5 weights may be screwed on. In conjunction with the Ex nA approval, a maximum of one additional weight is permitted for devices with external diameter of 29 mm (1.14 in).
- Order number 52006153, Product Configurator: the additional weight is optionally available.

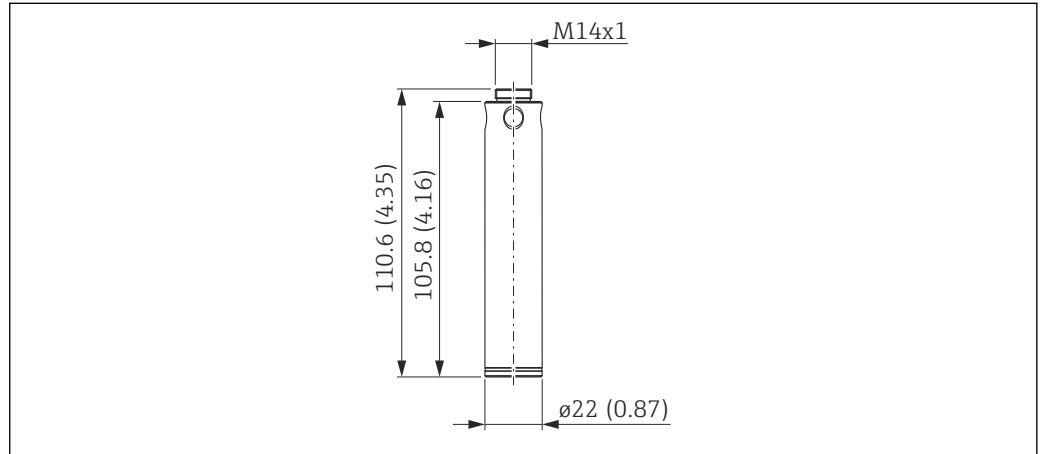

A0018748

Unit of measurement mm (in)

Testing adapter

For devices with external diameter of 22 mm (0.87 in) or 29 mm (1.14 in)

- Endress+Hauser offers a testing adapter to ease function-testing of the level probes.
- Observe the maximum pressure for compressed air hose and maximum overload for level probe → 14
- Maximum pressure for the quick coupling piece provided: 10 bar (145 psi)
- Adapter material: 304 (1.4301)
- Material of quick coupling piece: anodized aluminum
- Order number 52011868
Product Configurator: the testing adapter is optionally available.

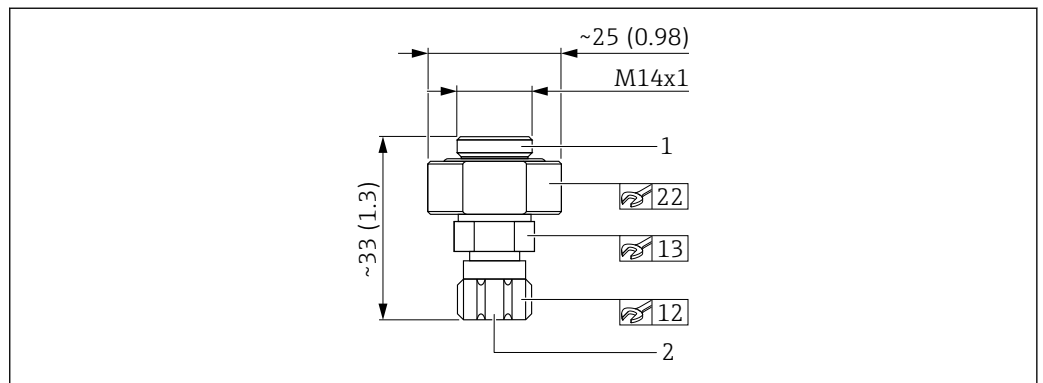

A0018749

Unit of measurement mm (in)

- 1 FMX21 level probe connection
- 2 Compressed air hose connection, internal diameter, quick coupling piece 4 mm (0.16 in)

RIA15 in the field housing

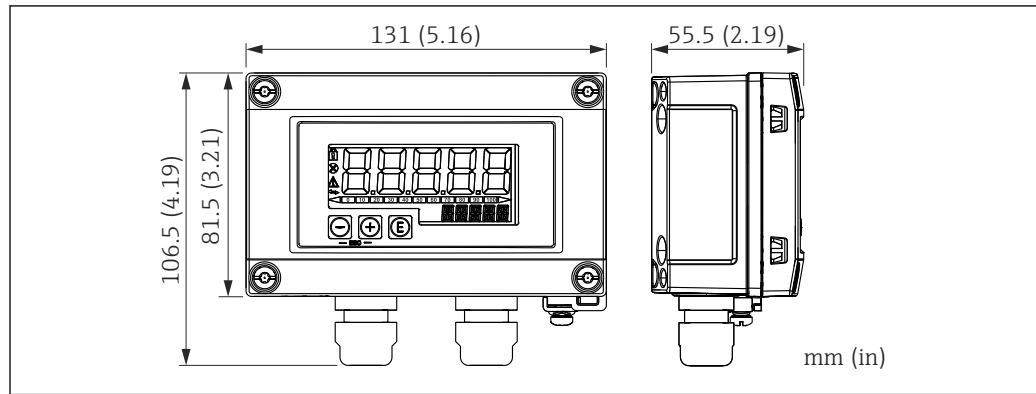

A0017722

5 Dimensions of RIA15 in field housing. Unit of measurement mm (in)

i The RIA15 remote display (for Ex or non-Ex area) can be ordered together with the device. See the Product Configurator.

b Alternatively available as an accessory, for details see Technical Information TI01043K and Operating Instructions BA01170K

HART communication resistor

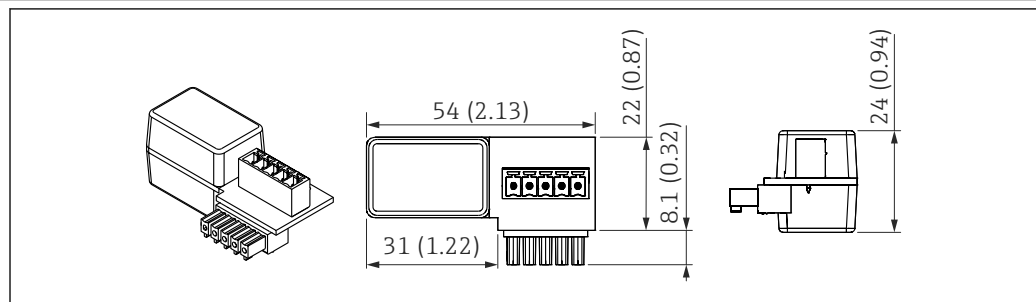

A0020858

6 Dimensions of HART communication resistor. Unit of measurement mm (in)

i A communication resistor is required for HART communication. If this is not already present (e.g. in the power supply RMA, RN221N, RNS221, ...), it can be ordered as an option via the Product Configurator.

b Alternatively available as an accessory, for details see Technical Information TI01043K and Operating Instructions BA01170K

The HART communication resistor is specially designed for use with the RIA15 and can be attached easily.

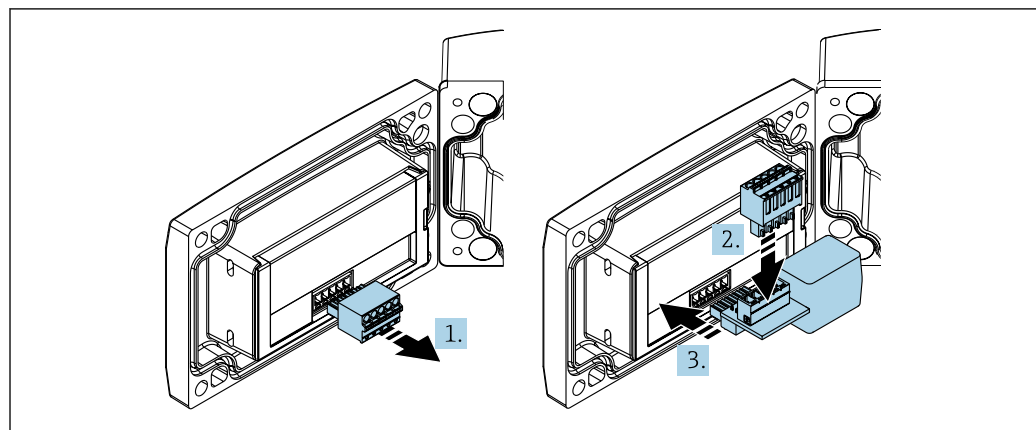

A0020844

1. Disconnect plug-in terminal block.
2. Insert the terminal block into the slot provided on the HART communication resistor module.

3. Insert the HART communication resistor in the slot in the housing.
-

Weight

- Level probe, external diameter of 22 mm (0.87 in):
344 g (12.133 oz)
- Level probe, external diameter of 42 mm (1.65 in):
1 376 g (48.532 oz)
- Level probe, external diameter of 29 mm (1.14 in):
394 g (13.896 oz)
- Extension cable:
 - PE: 52 g/m (0.035 lbs/1 ft)
 - PUR: 60 g/m (0.040 lbs/1 ft)
 - FEP: 108 g/m (0.072 lbs/1 ft)
- Suspension clamp:
170 g (5.996 oz)
- Cable mounting screw G 1½" A:
770 g (27.158 oz)
- Cable mounting screw NPT 1½":
724 g (25.535 oz)
- Terminal box:
235 g (8.288 oz)
- TMT71 temperature head transmitter:
40 g (1.411 oz)
- TMT72 temperature head transmitter:
40 g (1.411 oz)
- Additional weight:
300 g (10.581 oz)
- Testing adapter:
39 g (1.376 oz)

Materials

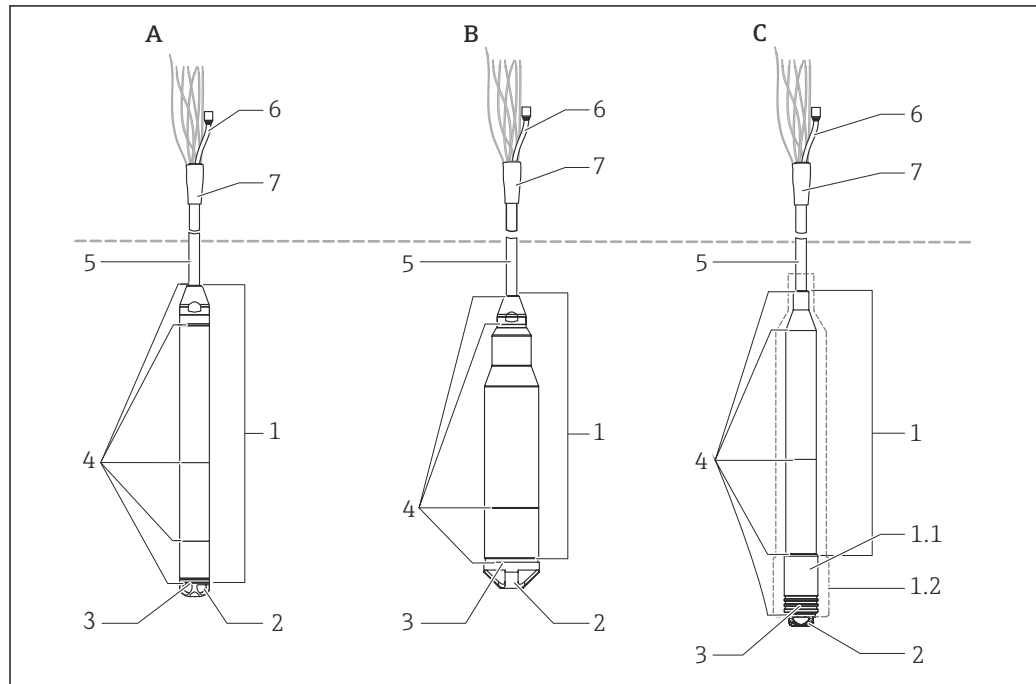

A0018787

Materials in contact with process**1 level probe**316L (1.4404/1.4435)²⁾

- **A:** External diameter 22 mm (0.87 in)
- **B:** External diameter 42 mm (1.65 in)
- **C:** External diameter max. 29 mm (1.14 in)

1.1 Sensor sleeve

PPS (Polyphenylene sulfide)

1.2 Heat shrink tube

Polyolefin and hot melt adhesive

i The heat-shrink tube around the level probe acts as insulation. It prevents electrical contact between the level probe and the tank. Electrochemical corrosion is thus avoided.

2 Protective cap

- For A and C: with external diameter 22 mm (0.87 in) and 29 mm (1.14 in) (order number: 52008999):

POM

- For B: device with external diameter 42 mm (1.65 in) (order number: 917755-0000):

PFA

3 Process ceramicAl₂O₃ (Aluminum oxide ceramic)**4 Seal**

- EPDM
- FKM Viton

5 Seal

Extension cable insulation, choose from:

- PE-LD (Low-density polyethylene)
- FEP (Fluorinated ethylene propylene)
- PUR (Polyurethane)

Materials not in contact with process**6 Pressure compensation tube**

PA

2) Material 316L (1.4404/1.4435) not in contact with the process in the case of level probe C

7 Heat shrink tube

Polyolefin

Terminal box (not in contact with process)

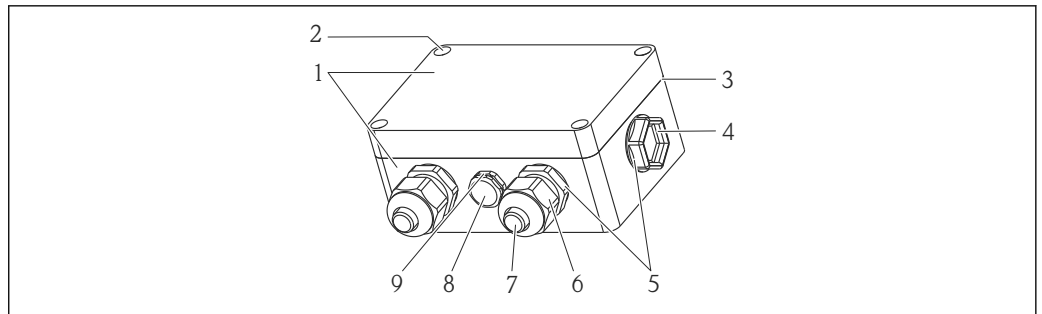

A0018917

1 Housing

PC

2 Mounting screws (4x)

A2

3 Seal

CR (Chloroprene rubber)

4 Dummy plug M20x1.5

PBT-GF30

5 Cable gland M20x1.5

PE-HD

6 Cable gland M20x1.5

PA6

7 Cable gland M20x1.5

PA6-GF30

8 Pressure compensation filter

PA6-GF10, ePTFE

9 Pressure compensation filter, O-ring

Silicone (VMQ)

Cable mounting screw (not in contact with process)

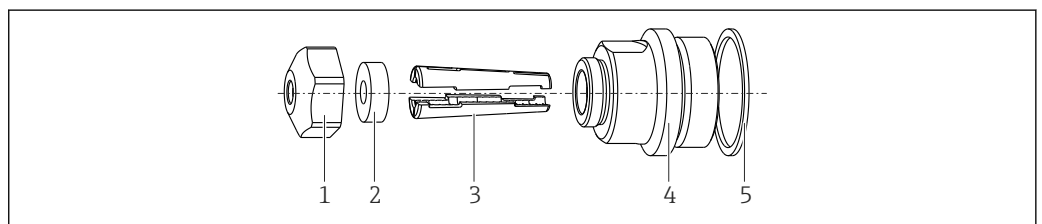

A0018918

1 Cover for cable mounting screw

304 (1.4301)

2 Sealing ring

NBR

3 Ferrules

PA66-GF35

4 Adapter for cable mounting screw G 1½" A, NPT 1½"

304 (1.4301)

5 Seal ® Only for G 1½" A

EPDM

Suspension clamp

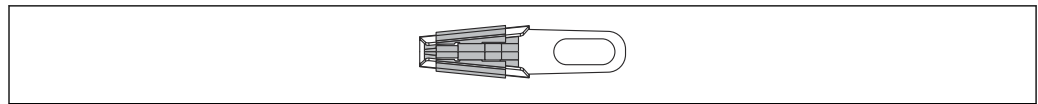

A0030950

Material: 316L (1.4404) and fiber-glass reinforced PA (polyamide)

Additional weight

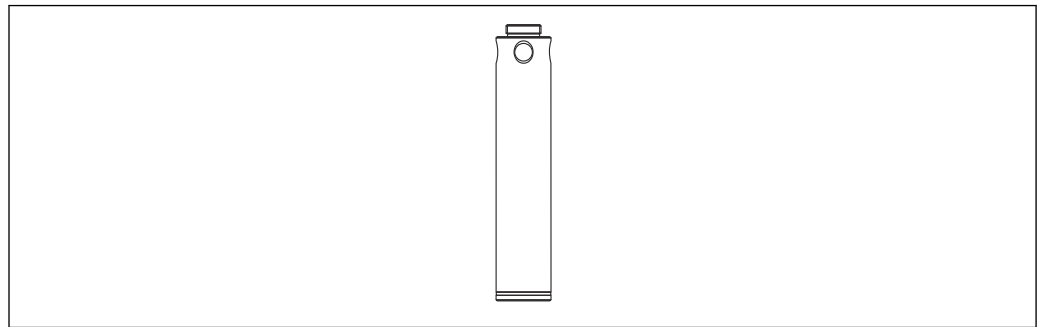

A0030954

Material: 316L (1.4435)

Testing adapter for devices with an external diameter of 22 mm (0.87 in) or 29 mm (1.14 in)

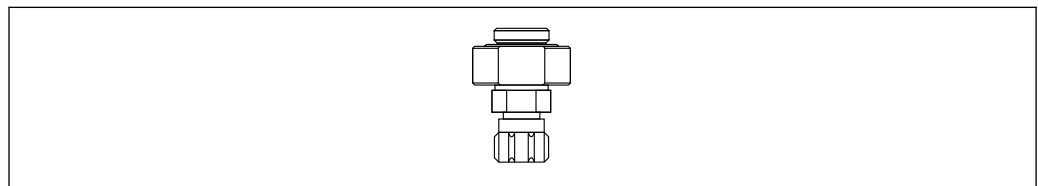

A0030956

Adapter material: 304 (1.4301)

Material of quick coupling piece: anodized aluminum

Testing adapter for devices with an external diameter of 42 mm (1.65 in)

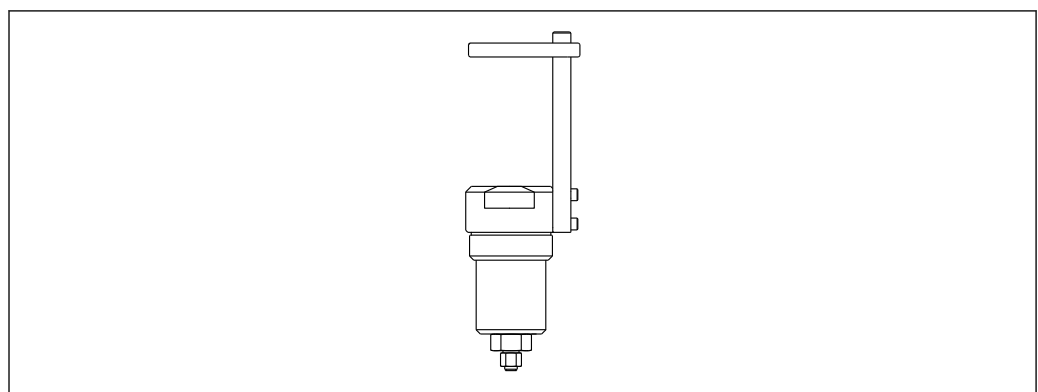

A0030957

Adapter material: 304 (1.4301)

Material of quick coupling piece: anodized aluminum

Extension cable

PE

- Abrasion-resistant extension cable with strain-relief members made of high-strength PE fibers
- Shielded (aluminum)
- Insulated with polyethylene (PE), black
- Copper wires, twisted
- Pressure compensation tube with Teflon filter

PUR

- Abrasion-resistant extension cable with strain-relief members made of high-strength PE fibers
- Shielded (aluminum)
- Insulated with polyurethane (PUR), black
- Copper wires, twisted
- Pressure compensation tube with Teflon filter

FEP

- Abrasion-resistant extension cable
- Shielded with galvanized steel wire netting
- Insulated with fluorinated ethylene propylene (FEP), black
- Copper wires, twisted
- Pressure compensation tube with Teflon filter

Operability

FMX21 4 to 20 mA Analog	No display or other operation facility is required to operate the device. However, the measured values can be read out with optional evaluation units.
FMX21 4 to 20 mA HART	<p>FieldCare</p> <p>FieldCare is an Endress+Hauser asset management tool based on FDT technology. With FieldCare, you can configure all Endress+Hauser devices as well as devices from other manufacturers that support the FDT standard.</p> <p>FieldCare supports the following functions:</p> <ul style="list-style-type: none"> ■ Configuration of transmitters in online and offline mode ■ Loading and saving device data (upload/download) ■ Documentation of the measuring point <p>Connection options:</p> <ul style="list-style-type: none"> ■ Via Commubox FXA195 and the USB interface of a computer ■ Via Fieldgate FXA520 <p>For additional information and free download of FieldCare, see → www.de.endress.com → Download → Text Search: FieldCare</p> <p>DeviceCare</p> <p><i>Function scope</i></p> <p>Tool for connecting and configuring Endress+Hauser field devices.</p> <p>The fastest way to configure Endress+Hauser field devices is with the dedicated "DeviceCare" tool. Together with the device type managers (DTMs) it presents a convenient, comprehensive solution.</p> <p> For details, see Innovation brochure IN01047S</p> <p>Field Xpert SFX</p> <p>Field Xpert SFX is an industrial PDA with integrated 3.5" touchscreen from Endress+Hauser based on Windows Mobile. It offers wireless communication via the optional VIATOR® Bluetooth® modem as a point-to-point connection to a HART device, or via WiFi and Endress+Hauser's Fieldgate FXA520 to one or more HART devices. Field Xpert also works as a stand-alone device for asset management applications. For details, refer to BA00060S/04/EN.</p>
RIA15	The RIA15 can be used as a local display unit and for the basic commissioning of the Waterpilot FMX21 hydrostatic level sensor via HART.

Certificates and approvals

Current certificates for the product are available on the product page at www.endress.com.

1. Select the product using the filters and search field.
2. Open the product page.
3. Select **Downloads**.
4. Select **Technical Documentation**.
5. Select **ZE (Certificates)** as the filter

A list of all the certificates appears.

Current approvals for the product are available on the product page at www.endress.com.

1. Select the product using the filters and search field.
2. Open the product page.
3. Select **Downloads**.
4. Select **Approvals**.

A list of all the approvals appears.

CE mark

The device meets the legal requirements of the relevant EC directives. Endress+Hauser confirms that the device has been successfully tested by applying the CE mark.

RCM marking

The supplied product or measuring system meets the ACMA (Australian Communications and Media Authority) requirements for network integrity, interoperability, performance characteristics as well as health and safety regulations. Here, especially the regulatory arrangements for electromagnetic compatibility are met. The products bear the RCM marking on the nameplate.



A0029561

EAC conformity

The measuring system meets the legal requirements of the applicable EAC guidelines. These are listed in the corresponding EAC Declaration of Conformity together with the standards applied.

Endress+Hauser confirms successful testing of the device by affixing to it the EAC mark.

Drinking water approval

The following drinking water approvals can be ordered optionally via the Product Configurator for devices with an outer diameter of 22 mm (0.87 in) with an EPDM seal:

- KTW
- NSF61
- ACS

Marine approval

The following marine approvals can be ordered optionally via the Product Configurator for devices with an outer diameter of 22 mm (0.87 in):

- GL
- ABS
- BV
- DNV

Other standards and guidelines	<p>The applicable European guidelines and standards can be found in the relevant EU Declarations of Conformity. The following standards were also applied:</p> <p>DIN EN 60770 (IEC 60770): Transmitters for use in industrial process control systems Part 1: Methods for performance evaluation Methods for evaluating the performance of transmitters for control and regulation in industrial process control systems.</p> <p>DIN 16086: Electrical pressure measuring instruments, pressure sensors, pressure transmitters, pressure measuring instruments, concepts, specifications on data sheets Procedure for writing specifications in data sheets for electrical pressure measuring instruments, pressure sensors and pressure transmitters.</p> <p>EN 61326: Electrical equipment for measurement, control and laboratory use – EMC requirements</p> <p>EN 61010-1 (IEC 61010-1): Safety requirements for electrical equipment for measurement, control and laboratory use</p> <p>EN 60529: Degrees of protection provided by enclosures (IP code)</p>
Calibration	<p>Factory calibration certificate, 5-point Product Configurator: the 5-point factory calibration certificate is optionally available.</p>
Calibration unit	<p>The following options can be selected in the Product Configurator:</p> <ul style="list-style-type: none"> ■ Sensor range; % ■ Sensor range; mbar/bar ■ Sensor range; kPa/MPa ■ Sensor range; mm/m H₂O ■ Sensor range; in H₂O/ft H₂O ■ Sensor range; psi ■ Customized pressure; see additional specification ■ Customized level; see additional specification
Service	<p>The following options can be optionally selected in the Product Configurator:</p> <ul style="list-style-type: none"> ■ Configured min alarm current ■ Configured HART Burst Mode PV ■ Adjusted density compensation ■ ... m cable marking>installation ■ ... ft cable marking>installation ■ Special version
Downloading the Declaration of Conformity	<p>www.endress.com → Download</p>

Ordering information

Detailed ordering information is available from the following sources:

- In the Product Configurator on the Endress+Hauser website: www.endress.com-> Click "Corporate" -> Select your country -> Click "Products" -> Select the product using the filters and search field -> Open product page -> The "Configure" button to the right of the product image opens the Product Configurator.
- From your Endress+Hauser sales organization: www.addresses.endress.com



Product Configurator - the tool for individual product configuration

- Up-to-the-minute configuration data
- Depending on the device: direct input of information specific to the measuring point, such as the measuring range or operating language
- Automatic verification of exclusion criteria
- Automatic creation of the order code and its breakdown in PDF or Excel output format
- Ability to order directly in the Endress+Hauser Online Shop

Scope of delivery

- Measuring device
- Optional accessories
- Brief Operating Instructions
- Certificates

Test reports, declarations and inspection certificates

All test reports, declarations and inspection certificates are provided electronically in the *W@M Device Viewer*:

Enter the serial number from the nameplate (www.endress.com/deviceviewer)



Product documentation on paper

Test reports, declarations and inspection certificates in hard copy can optionally be ordered with feature 570 "Service", Version I7 "Product documentation on paper". The documents are then provided with the device upon delivery.

Configuration data sheet

Level

The following configuration data sheet must be completed and included with the order if option "K: customized level" has been selected for order code "090: Calibration; unit" in the product structure.

Pressure unit	Output unit (scaled unit)																																								
<input type="checkbox"/> mbar <input type="checkbox"/> mmH ₂ O <input type="checkbox"/> mmHg <input type="checkbox"/> Pa <input type="checkbox"/> bar <input type="checkbox"/> mH ₂ O <input type="checkbox"/> kPa <input type="checkbox"/> ftH ₂ O <input type="checkbox"/> MPa <input type="checkbox"/> psi <input type="checkbox"/> inH ₂ O <input type="checkbox"/> kgf/cm ²	<table style="width: 100%; border-collapse: collapse;"> <tr> <td style="width: 15%;">Mass</td> <td style="width: 15%;">Lengths</td> <td style="width: 15%;">Volume</td> <td style="width: 15%;">Volume</td> <td style="width: 15%;">Percent</td> </tr> <tr> <td><input type="checkbox"/> kg</td> <td><input type="checkbox"/> m</td> <td><input type="checkbox"/> l</td> <td><input type="checkbox"/> gal</td> <td><input type="checkbox"/> %</td> </tr> <tr> <td><input type="checkbox"/> t</td> <td><input type="checkbox"/> dm</td> <td><input type="checkbox"/> hl</td> <td><input type="checkbox"/> lgal</td> <td></td> </tr> <tr> <td><input type="checkbox"/> lb</td> <td><input type="checkbox"/> cm</td> <td></td> <td></td> <td></td> </tr> <tr> <td></td> <td><input type="checkbox"/> mm</td> <td><input type="checkbox"/> m³</td> <td></td> <td></td> </tr> <tr> <td></td> <td></td> <td><input type="checkbox"/> ft³</td> <td></td> <td></td> </tr> <tr> <td></td> <td><input type="checkbox"/> ft</td> <td><input type="checkbox"/> in³</td> <td></td> <td></td> </tr> <tr> <td></td> <td><input type="checkbox"/> inch</td> <td></td> <td></td> <td></td> </tr> </table>	Mass	Lengths	Volume	Volume	Percent	<input type="checkbox"/> kg	<input type="checkbox"/> m	<input type="checkbox"/> l	<input type="checkbox"/> gal	<input type="checkbox"/> %	<input type="checkbox"/> t	<input type="checkbox"/> dm	<input type="checkbox"/> hl	<input type="checkbox"/> lgal		<input type="checkbox"/> lb	<input type="checkbox"/> cm					<input type="checkbox"/> mm	<input type="checkbox"/> m ³					<input type="checkbox"/> ft ³				<input type="checkbox"/> ft	<input type="checkbox"/> in ³				<input type="checkbox"/> inch			
Mass	Lengths	Volume	Volume	Percent																																					
<input type="checkbox"/> kg	<input type="checkbox"/> m	<input type="checkbox"/> l	<input type="checkbox"/> gal	<input type="checkbox"/> %																																					
<input type="checkbox"/> t	<input type="checkbox"/> dm	<input type="checkbox"/> hl	<input type="checkbox"/> lgal																																						
<input type="checkbox"/> lb	<input type="checkbox"/> cm																																								
	<input type="checkbox"/> mm	<input type="checkbox"/> m ³																																							
		<input type="checkbox"/> ft ³																																							
	<input type="checkbox"/> ft	<input type="checkbox"/> in ³																																							
	<input type="checkbox"/> inch																																								
Empty calibration [a]: Low pressure value (empty) _____ <div style="text-align: right;">[pressure engineering unit]</div>	Empty calibration [a]: Low measured value (empty) _____ <div style="text-align: right;">[scaled unit]</div>																																								
Full calibration [b]: High pressure value (full) _____ <div style="text-align: right;">[pressure engineering unit]</div>	Full calibration [b]: High measured value (full) _____ <div style="text-align: right;">[scaled unit]</div>																																								

Damping

Damping: _____ sec

Pressure

The following configuration data sheet must be completed and included with the order if option "J: customized pressure" has been selected for order code "090: Calibration; unit" in the product structure.

Pressure unit

- | | | | |
|-------------------------------|---|--|------------------------------|
| <input type="checkbox"/> mbar | <input type="checkbox"/> mmH ₂ O | <input type="checkbox"/> mmHg | <input type="checkbox"/> Pa |
| <input type="checkbox"/> bar | <input type="checkbox"/> mH ₂ O | | <input type="checkbox"/> kPa |
| | <input type="checkbox"/> ftH ₂ O | | <input type="checkbox"/> MPa |
| <input type="checkbox"/> psi | <input type="checkbox"/> inH ₂ O | <input type="checkbox"/> kgf/cm ² | |

Calibration range / Output

Lower-range value (LRV):	_____	[pressure engineering unit]
Upper-range value (URV):	_____	[pressure engineering unit)]

Damping

Damping: _____ sec

Accessories

- i
 - Observe the additional information in the individual sections!
 - For additional information, see the sections "Mechanical construction" → [34](#), "Environment", → [30](#), "Process" → [32](#) and "Mounting" → [27](#).

Suspension clamp

For easy installation of the device, Endress+Hauser offers a suspension clamp.

- Product Configurator: the suspension clamp is optionally available
- Order number: 52006151

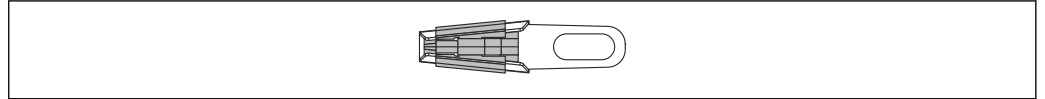

A0030950

Terminal box

Terminal box for terminal strip, temperature head transmitter and Pt100.

- Product Configurator: the terminal box is optionally available
- Order number: 52006152

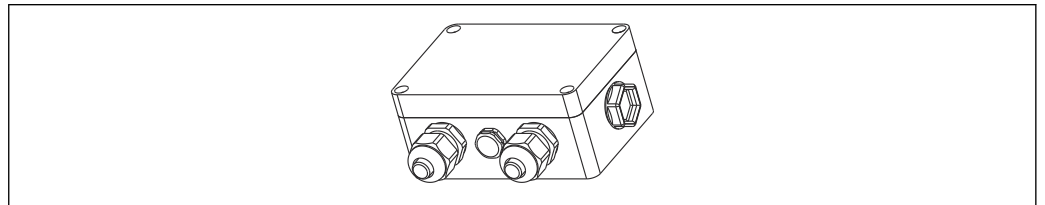

A0030967

4-terminal strip/terminals

4-terminal strip for wiring

Order number: 52008938

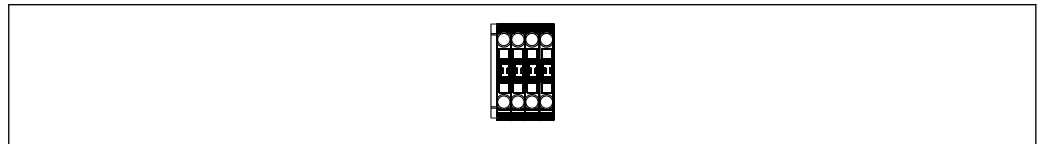

A0030951

Temperature head transmitter TMT71 for FMX21 4 to 20 mA analog

PC-programmable (PCP) temperature head transmitter for the conversion of various input signals.

- Product Configurator: the temperature head transmitter TMT71 is optionally available → [51](#)
- Order number: 52008794

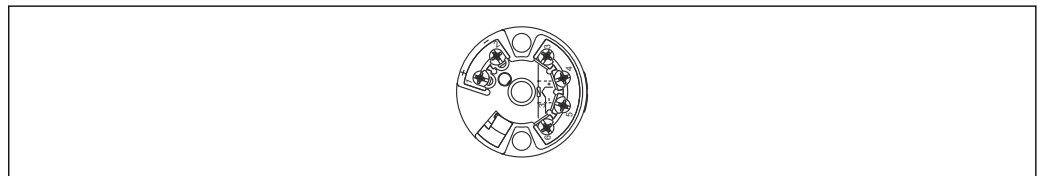

A0030952

Temperature head transmitter TMT72 for FMX21 4 to 20 mA HART

PC-programmable (PCP) temperature head transmitter for the conversion of various input signals.

- Product Configurator: the temperature head transmitter TMT72 is optionally available
- Order number: 51001023

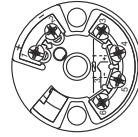

A0030952

Cable mounting screws

Endress+Hauser offers a cable mounting screw for easy device mounting and to seal the measuring aperture.

- G 1½" A
Order number: 52008264
- NPT 1½"
Order number: 52009311
- Product Configurator: the cable mounting screws are optionally available

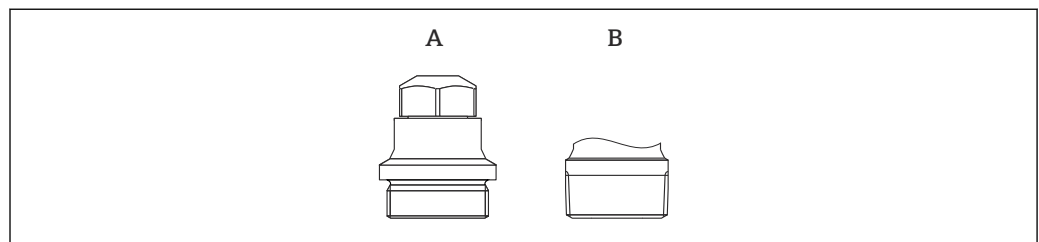

A0030953

- A G 1½" A
B NPT 1½"

Additional weight for device with an outer diameter of 22 mm (0.87 in) or 29 mm (1.14 in)

Endress+Hauser offers additional weights to prevent sideways movement that results in measuring errors, or to make it easier to lower the device in a guide tube.

- Product Configurator: the additional weight is optionally available
- Order number: 52006153

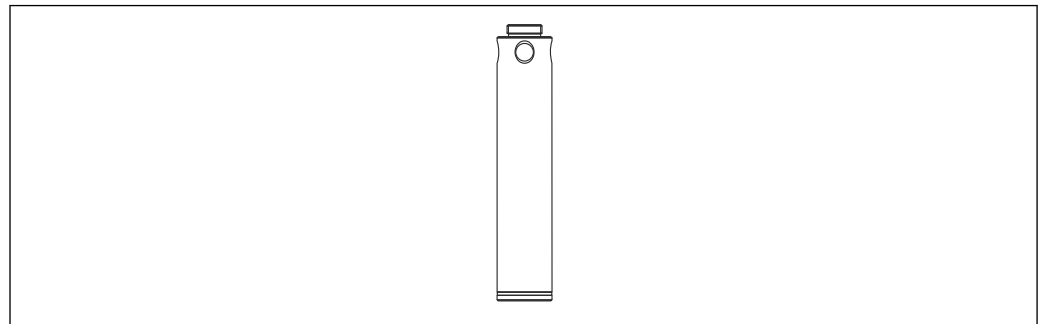

A0030954

Cable shortening kit

The cable shortening kit is used to shorten a cable easily and professionally.

- Product Configurator: the cable shortening kit is optionally available
- Order number: 71222671

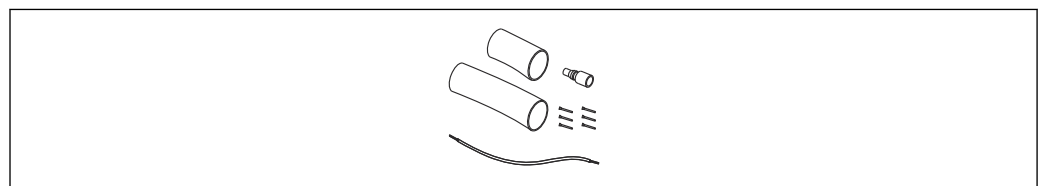

A0030948

Testing adapter for devices with an external diameter of 22 mm (0.87 in) or 29 mm (1.14 in)

Endress+Hauser offers a testing adapter to ease function-testing of the level probes.

- Product Configurator: the testing adapter is optionally available
- Order number: 52011868

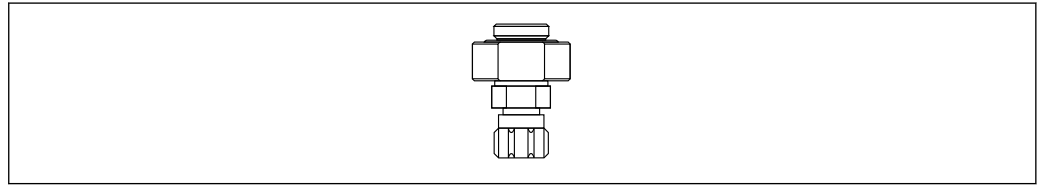

A0030956

Testing adapter for devices with an external diameter of 42 mm (1.65 in)

Endress+Hauser offers a testing adapter to ease function-testing of the level probes.

- Observe the maximum pressure for compressed air hose and maximum overload for level probe
- Maximum pressure for the quick coupling piece provided: 10 bar (145 psi)
- Order number: 71110310

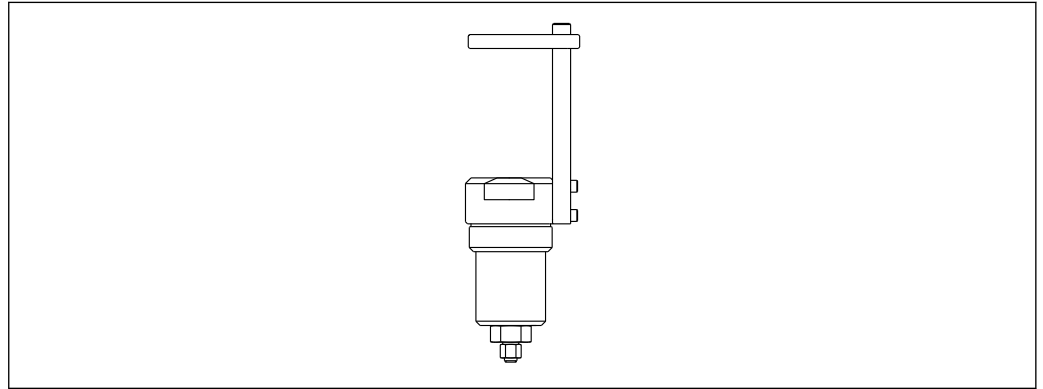

A0030957

RIA15 in the field housing

- Remote display RIA15 non-hazardous
 - ↳ Product structure: the display is optionally available
- Remote display RIA15 hazardous
 - ↳ Product structure: the display is optionally available

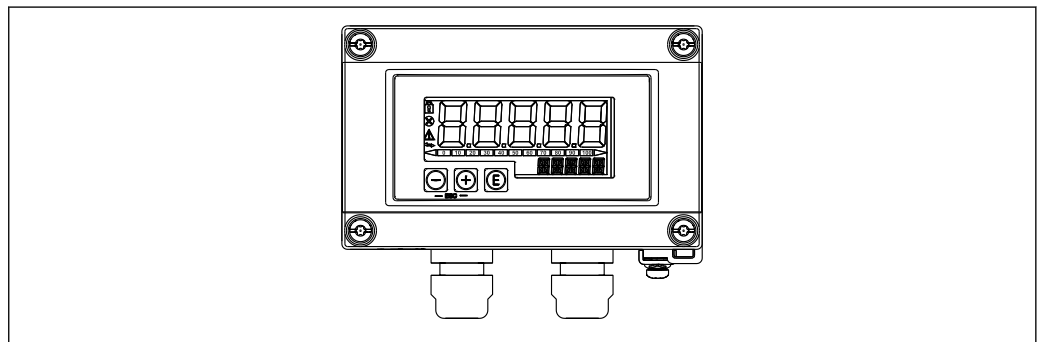

A0036164

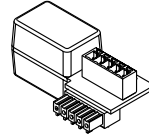

HART communication resistor

- HART communication resistor hazardous / non-hazardous area, for use with RIA15
- Product structure: the HART communication resistor is optionally available



A0036165

Service-specific accessories

Accessories	Description
DeviceCare SFE100	Configuration tool for HART, PROFIBUS and FOUNDATION Fieldbus field devices  Technical Information TI01134S  DeviceCare is available for download at www.software-products.endress.com . You need to register in the Endress+Hauser software portal to download the application.
FieldCare SFE500	FDT-based plant asset management tool FieldCare can configure all smart field units in your plant and helps you manage them. By using the status information, FieldCare is also a simple but effective way of checking the status and condition of the field devices.  Technical Information TI00028S

Supplementary documentation

The following document types are also available in the Downloads area of the Endress+Hauser website: www.endress.com → Downloads

Field of Activities	<ul style="list-style-type: none"> ■ Pressure measurement: FA00004P/00/EN ■ Recording technology: FA00014R/09/EN ■ System components: FA00016K/09/EN
Technical Information	<ul style="list-style-type: none"> ■ Deltapilot M: TI00437P/00/EN ■ Temperature head transmitter iTEMP TMT71: TI01393T ■ Temperature head transmitter iTEMP HART TMT72: TI01392T ■ RIA15: TI01043K/09/EN
Operating Instructions	<ul style="list-style-type: none"> ■ Waterpilot FMX21 4 to 20 mA Analog: BA01605P/00/EN ■ Waterpilot FMX21 4 to 20 mA HART: BA00380P/00/EN ■ RIA15: BA01170K/09/EN ■ Cable shortening kit: SD00552P/00/A6 ■ Field Xpert: BA01211S/04/EN
Brief Operating Instructions	<ul style="list-style-type: none"> ■ Waterpilot FMX21 4 to 20 mA Analog: KA01244P/00/EN - Brief Operating Instructions for the device ■ Waterpilot FMX21 4 to 20 mA HART: KA01189P/00/EN - Brief Operating Instructions for the device
Safety Instructions (XA)	<p>Depending on the approval, Safety Instructions (XA) are supplied with the device. The Safety Instructions are an integral part of the Operating Instructions.</p> <p> The nameplate indicates the Safety Instructions (XA) that are relevant to the device.</p>
Drinking water approval	<ul style="list-style-type: none"> ■ SD00289P/00/A3 (NSF) ■ SD00319P/00/A3 (KTW) ■ SD00320P/00/A3 (ACS)

Registered trademarks

GORE-TEX®	Trademark of W.L. Gore & Associates, Inc., USA.
TEFLON®	Trademark of E.I. Du Pont de Nemours & Co., Wilmington, USA.
HART®	Registered trademark of the FieldComm Group, Austin, USA
FieldCare®	Trademark of Endress+Hauser Process Solutions AG.
DeviceCare®	Trademark of Endress+Hauser Process Solutions AG.
iTEMP®	Trademark of Endress+Hauser Wetzler GmbH + Co. KG, Nesselwang, D..



71593286

www.addresses.endress.com
