

Differential pressure level transmitter

Model: PT124B-3504



Description

The diaphragm seal of PT124B-3504 differential pressure level transmitter is single flange mounting type, it is used to prevent medium from entering directly into the pressure-sensing assembly of the pressure transmitter. It is connected to the transmitter using capillary filled with fill fluid, such as silicon oil. The model PT124B-3504 can be used to measure liquid, gas, or steam flow, as well as liquid level, density and pressure. It outputs a 4 to 20mA DC HART signal corresponding to the measured pressure differential. The model PT124B-3504 also features remote setup and monitoring through communication with the model RST375 TERMINAL or RSM100 Modem. PT124B-3504 differential pressure level transmitter span ranges (non migration) is 0 to 1KPa to 2MPa, and the rated pressure of the liquid level flange is 1.6/4MPa, 6.4MPa, 10MPa, 150psi, 300psi or 600psi.

Feature

- Adopts global leading high precision silicon
- Strong anti-jamming performance
- Accuracy +/-0.075%
- Advanced stability and static pressure performance
- Error less than +/-0.1%/10MPa
- Internal integrated high sensitivity temperature transducer
- Perfect thermal drift
- Fast response time



Specification

Measurement parameter	gauge pressure, absolute pressure, liquid level
Measurement range (Non migration)	0-1KPa-2MPa
Accuracy	+/-0.1%
Wetted parts material	SS316L, Hastelloy C, tantalum. FEP, PFA, PTEE membrane tectoria
Output	2-wire 4-20mA, HART communication optional, linear output or square root output available
Ambient temperature limited	Lowest: depending on the filled liquid Highest: 85°C -20~65°C (with LCD display, fluorine rubber O-ring)
temperature limited	-30~400°C
Protection grade	IP67
Electrical connector	M20*1.5 cable sealing buckle, terminal suitable for 0.5-2.5mm ² cable
Process connector	7/16 female at the low pressure, compatible with ANSI or DIN at high pressure. Directly install.

Dimensions

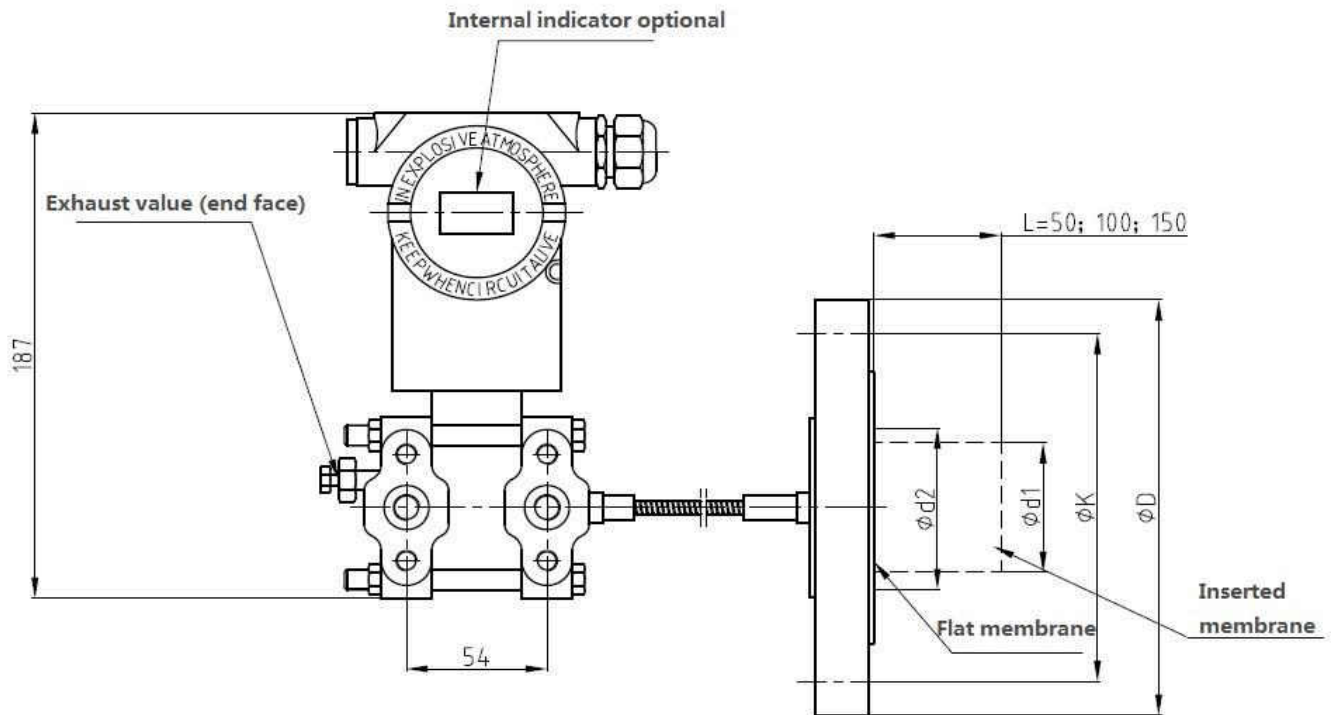

Flange size table

Standard Diameter	Rated Pressure	ϕD	ϕK	$\phi d1$		$\phi d3$	t	b	Mating bolt	
				Inserted	Flat				QTY	Screw
DN50 (Seal face DIN 2526E) (Flange DIN2501)	PN1.6/4MPa	165	125	48.3	57	102	3+0.5	20	4	M16
	PN6.4MPa	18	135	48.3	57	102	3+0.5	26	4	M20
	PN10MPa	195	145	48.3	57	102	3+0.5	28	4	M20
DN80 (Seal face DIN 2526E) (Flange DIN2501)	PN1.6/4MPa	200	160	76	75	138	3+0.5	24	8	M16
	PN6.4MPa	215	170	76	75	138	3+0.5	28	8	M20
	PN10MPa	230	180	76	75	138	3+0.5	32	8	M24
DN 2" (ANSI B 16.5RF)	150psi	152.4	120.6	48.3	57	92.1	3+0.5	17.4	4	M18
	300psi	165.1	127.0	48.3	57	92.1	3+0.5	20.6	8	M18
	600psi	165.1	127.0	48.3	57	92.1	6.35	31.75	8	M18
DN 2" (ANSI B 16.5RF)	150psi	190.5	152.4	76	75	127	3+0.5	22.2	4	M16
	300psi	209.5	168.3	76	75	127	3+0.5	27	8	M20
	600psi	209.5	168.3	76	75	127	6.35	38.05	8	M20
DN 4" (ANSI B 16.5RF)	150psi	229	191	89	89	57	3+0.5	30	8	M18
	300psi	255	200	89	89	57	3+0.5	32	8	M18

Wiring connector

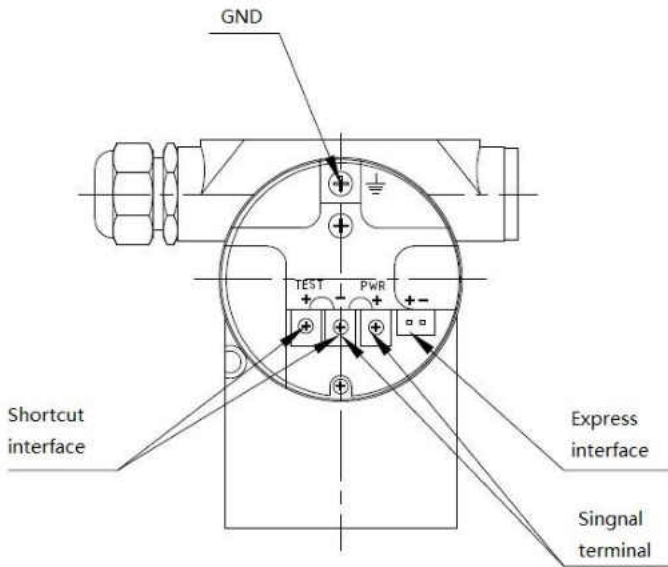

PIN	2-wire	3-wire
PWR+	P+	P+
PWR-	P-	P-
TEST+		S-

Process connector

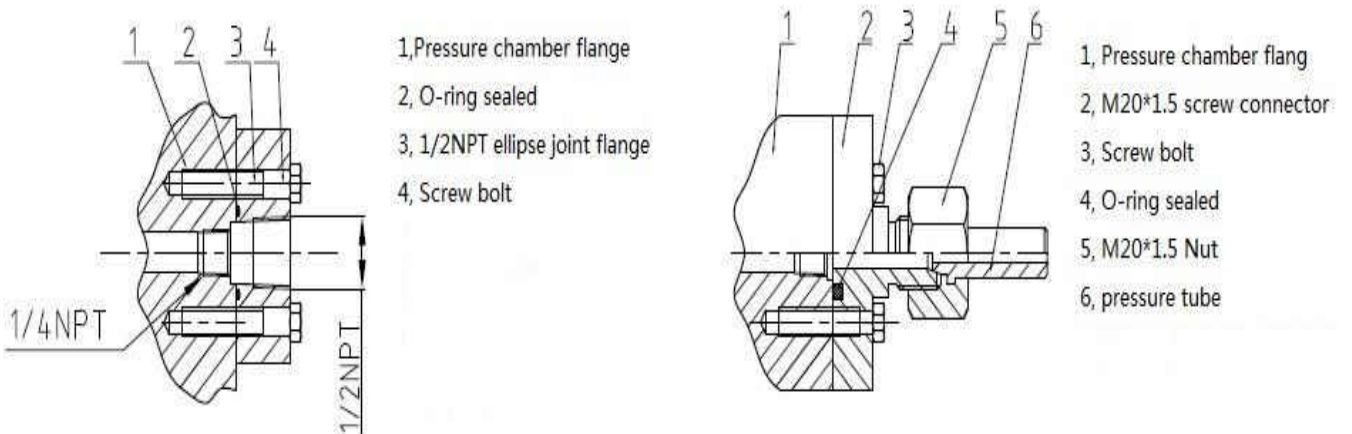

Ordering Guide

Model	Range	Output	Screw Thread	connection	Other requirement
PT124B-3504	---	---	---	---	---

Example: PT124B-3504-10mbar-4/20mA(HART)-DN80- 1/2NPT F

Shanghai Zhaohui Pressure Apparatus Co.,Ltd

5-6F No.8 Building No.115 ,Lane 1276 Nanle Road Songjiang District Shanghai 201600 China
 Tel:+86-21-51691919 67755189 Fax:+86-21-67755185
 E-mail: info@zhyqsensor.com
 www.zhyqsensor.com

